

**SERVICE MANUAL**  
**WITH PARTS CATALOGUE**  
**FOR**  
**AUTOMATIC YARN CHANGER**

**YC 6**

C O N T E N T S

[1] COMPONENTS OF YC6.....	1
[2] YC6 DISASSEMBLY, ASSEMBLY, AND ADJUSTMENT.....	2
2-1 YC6 DISASSEMBLY AND ASSEMBLY.....	2
2-2 YC6 FUNCTIONAL CHECK POINTS.....	13
2-3 YC6 ADJUSTMENT WITH RIBBER ARM.....	15
2-4 YC6 ADJUSTMENT WITH YC ARM.....	20
2-5 CHECK POINTS FOR POSSIBLE INTERFERENCE.....	23
[3] YC ARM DISASSEMBLY, ASSEMBLY, AND ADJUSTMENT.....	24
3-1 YC ARM ADJUSTMENT.....	24
3-2 YC ARM DISASSEMBLY AND ASSEMBLY.....	28
[4] NECESSARY NOTES WHEN OPERATING YC6.....	33
[5] APPLICABLE MODELS.....	35
YC6 PARTS CATALOGUE.....	36

[1] COMPONENTS OF YC6

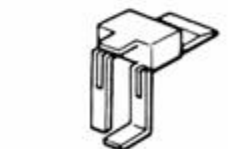
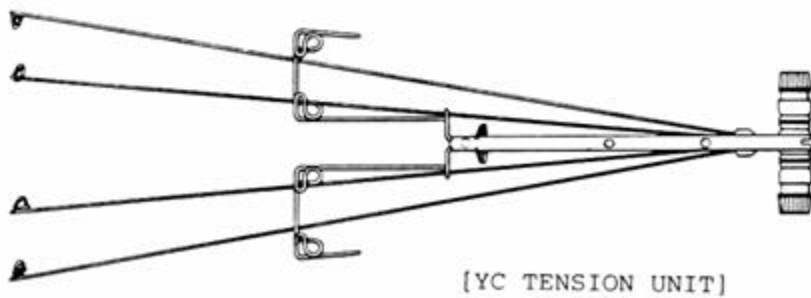
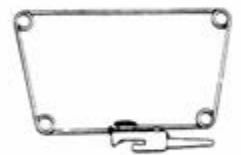
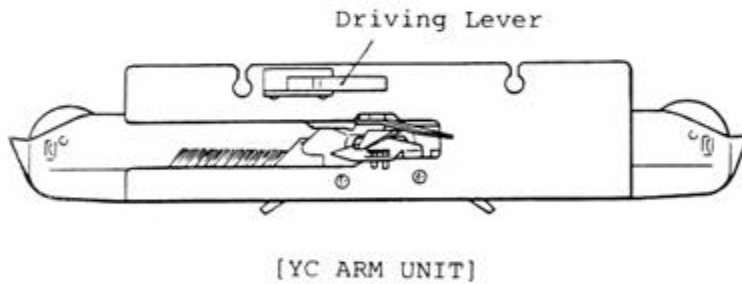
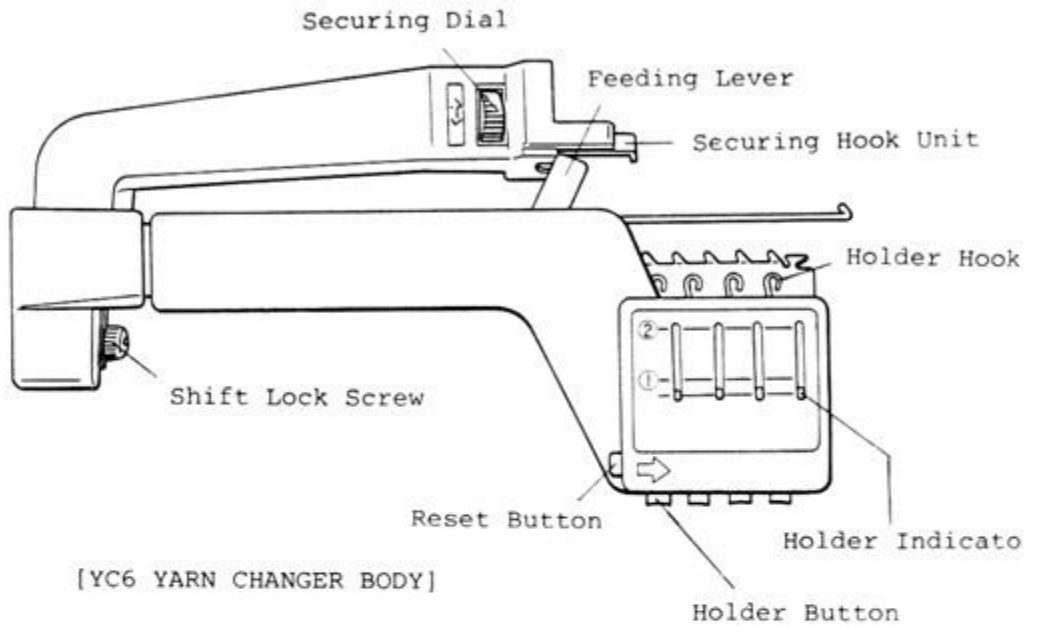

---

[2] YC6 DISASSEMBLY, ASSEMBLY, AND ADJUSTMENT

---

2-1 YC6 DISASSEMBLY AND ASSEMBLY

(1) Holder Securing Plate, YC Cover Unit, and Yarn Guide  
Removal and Installation

Removal:

1. Remove Binding Head STT Screw 3x6 and Binding Head Tapping Screw 2, 3x15 (one on left side shown in Figure). Holder Securing Plate will separate from YC Base.
2. Remove two Binding Head Tapping Screws 2, 3x8 and remaining one Binding Head Tapping Screw 2, 3x15.

(Note) YC Cover Unit will be free from YC Base. But, follow the procedure outlined in the step (3) to remove it.

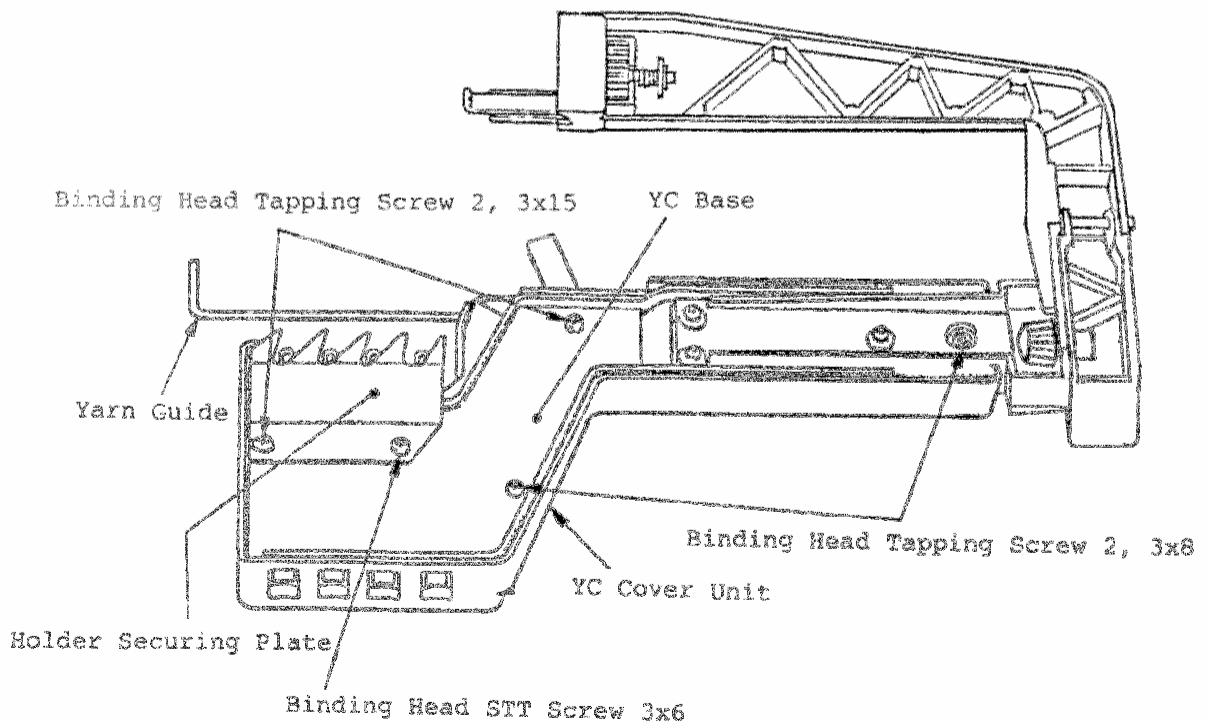

3. Carefully remove YC Cover Unit in the following manner, since Holder Buttons and other internal parts are apt to slip out of the YC Base.

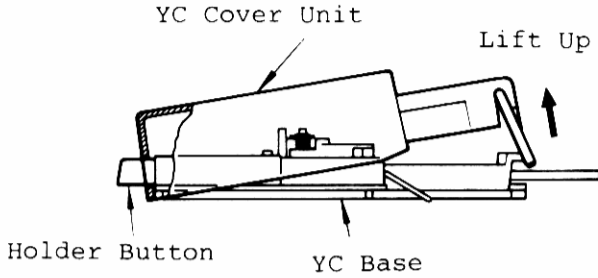

Lift up the rear side of YC Cover Unit slightly. This must be done with care as the Yarn Guide is apt to slip off.

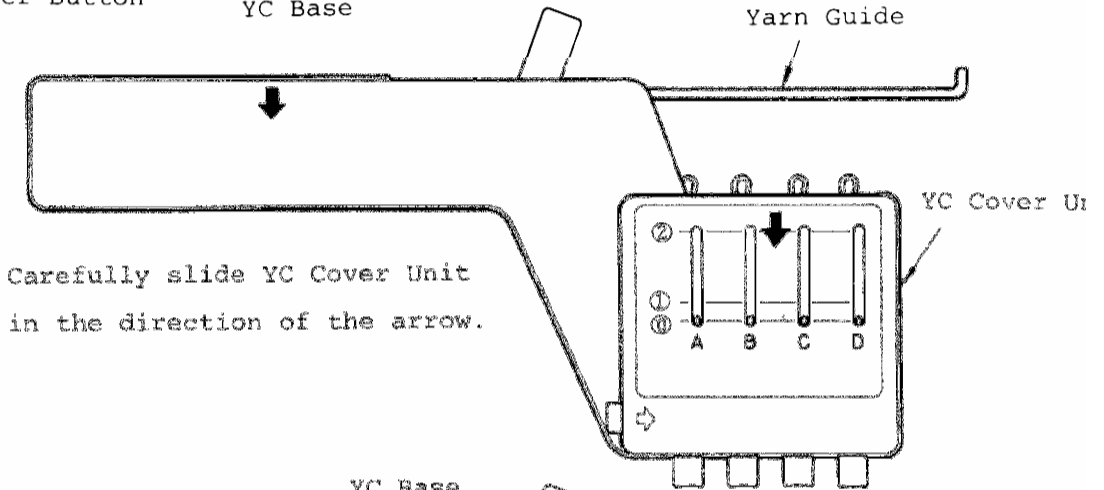

Carefully slide YC Cover Unit in the direction of the arrow.

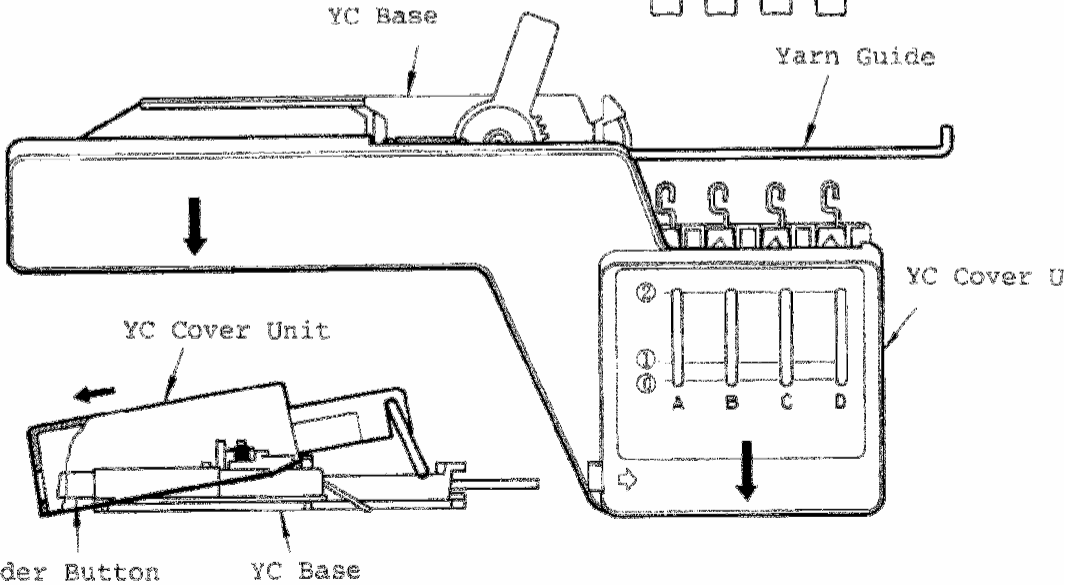

Remove YC Cover Unit from YC Base after it clears Holder Buttons.

4. Remove Yarn Guide snapped in YC Cover Unit.

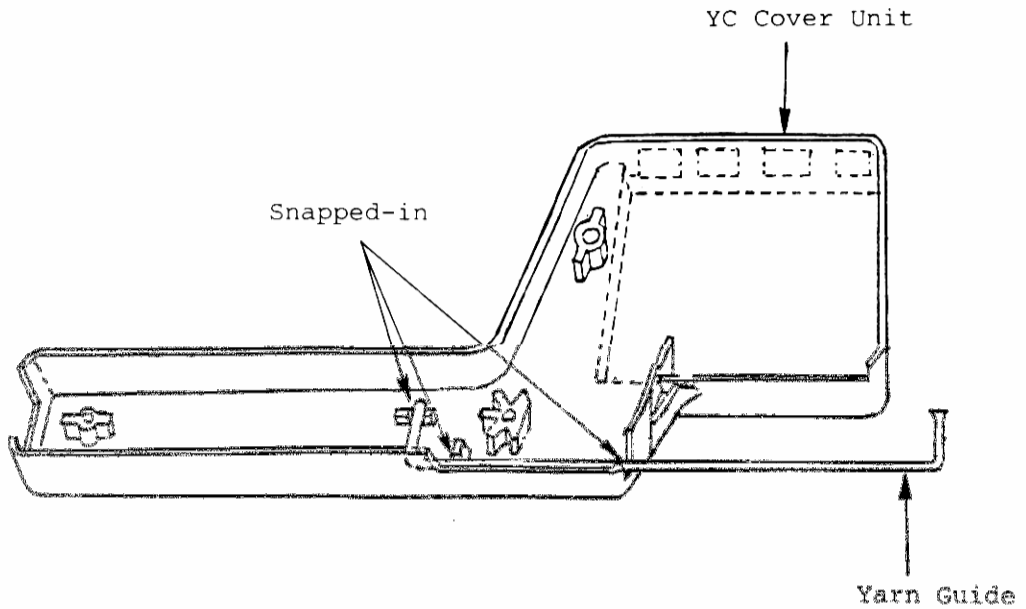

Installation: Reverse the procedure to install them.

(Notes at installation)

\*Do not overtorque Binding Head Tapping Screws. Overtightening of those screws may result in improper functioning of Feeding Lever and Holder Buttons.

\*Do not damage the teeth of Holder Securing Plate. Scratches or bend of the teeth may cause the dropped stitches.

(2) Feeding Slider, Gear, and Lever Removal and Installation

Removal:

1. Remove Feeding Slider Spring.
2. Remove Feeding Slider.
3. Remove Feeding Gear, while fitting the phase marks on both Feeding Lever and Gear.
4. Remove Feeding Lever Spring.
5. Remove Feeding Lever.

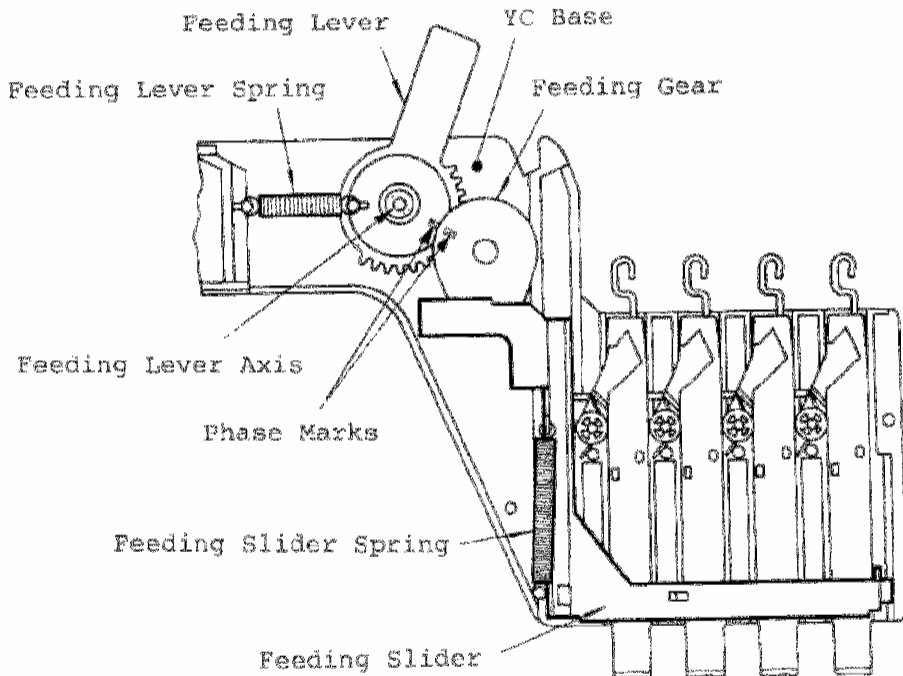

Installation: Reverse the procedure to install them.

(Notes at installation)

\*Check for no burrs, dust or lint around YC Base, Feeding Gear, and Feeding Lever. If exist, dress the burrs and remove dust or lint as they may cause improper functioning.

\*Set the Feeding Lever and Gear with both phase marks fitted accurately.

\*Ensure Feeding Lever Axis (See Figure on P.5) extends above the top surface of Feeding Lever. If not, Feeding Lever may not rotate smoothly.

\*Check for smooth travel of Feeding Slider.

### (3) Pre-set Bar Removal and Installation

Removal:

1. Remove Pre-set Spring on Pre-set Bar.
2. Move the Pre-set Bar in the arrow direction out of Feeding Slider.

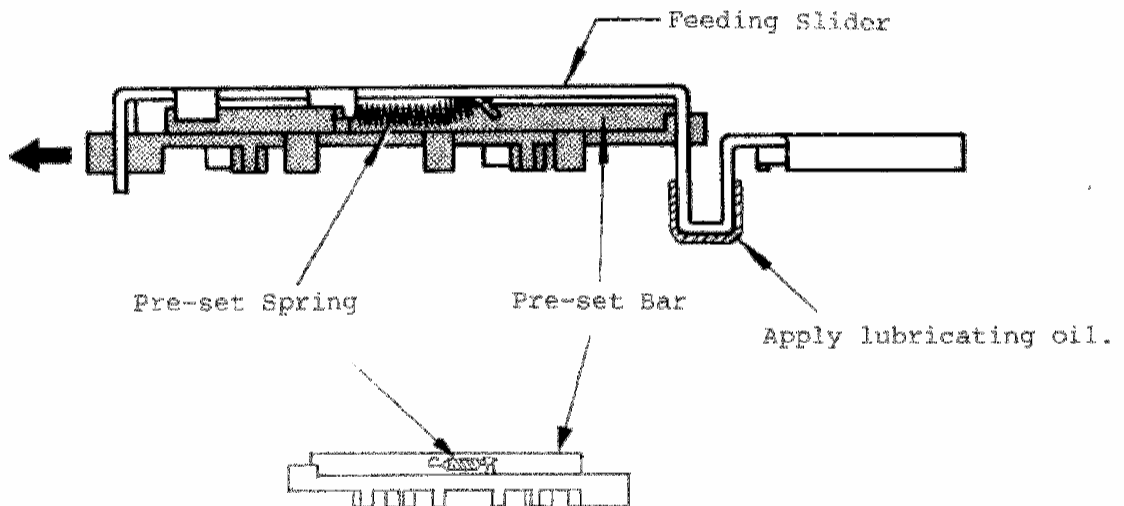

Installation: Reverse the procedure to install it.

(Notes at installation)

\*Check the Pre-set Bar for freedom of the movement. Particularly, check for no burrs around the openings of Feeding Slider as they may cause improper functioning of Pre-set Bar and Holder Buttons.



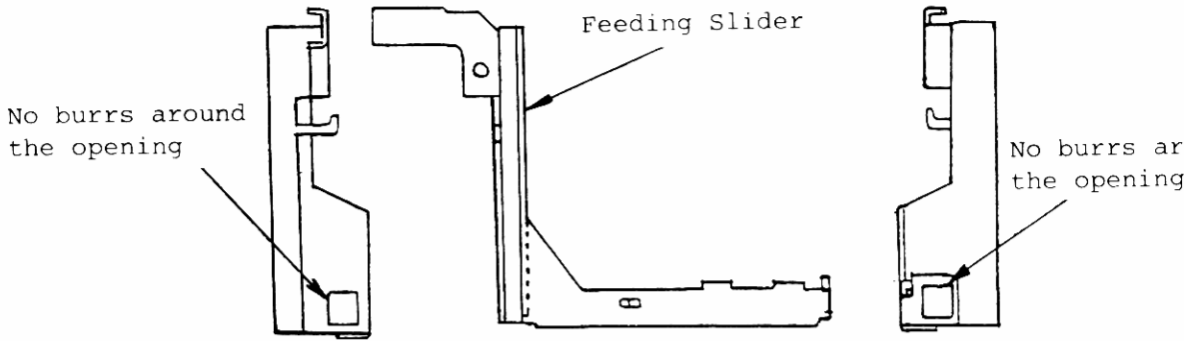

\*When replacing Feeding Slider, apply lubricating oil to its sliding part. (See Figure on P.6)

#### (4) Holder Stopper Removal and Installation

Removal:

1. Remove CS Snap Ring 3.

(Note) Take care not to break the plastic pin on YC Base when removing CS Snap Ring.

2. Remove Stopper Spring, also Holder Stopper.

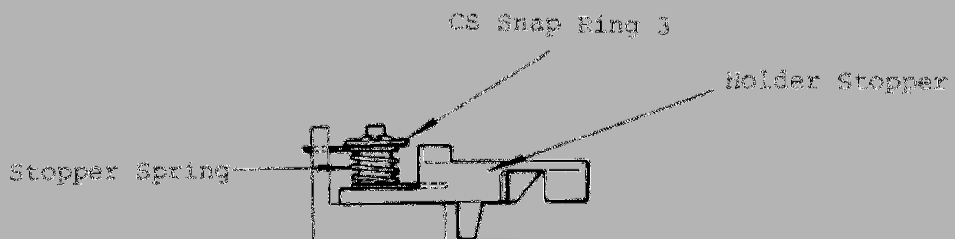
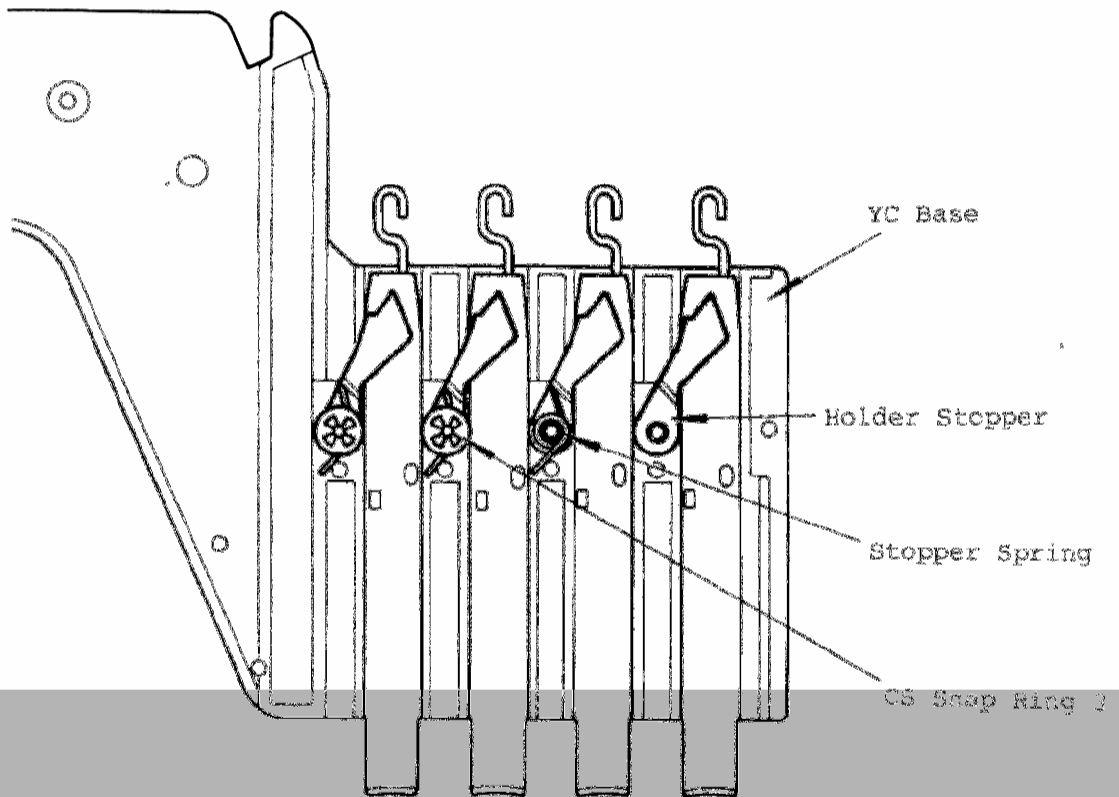

Installation: Reverse the procedure to install it.

(Notes at installation)

\*CS Snap Ring should be installed, while Stopper Spring is fully compressed with fingertip.

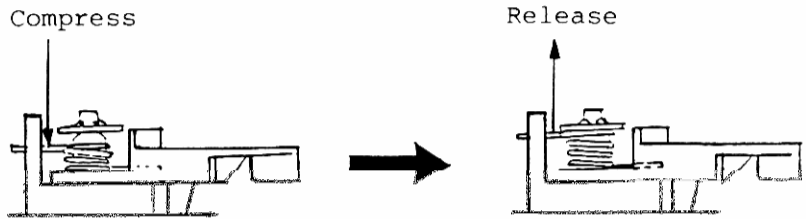

#### (5) Holder Button Removal and Installation

Removal:

1. Turn the Holder Stopper from A to B position so that Holder Button can be removed.

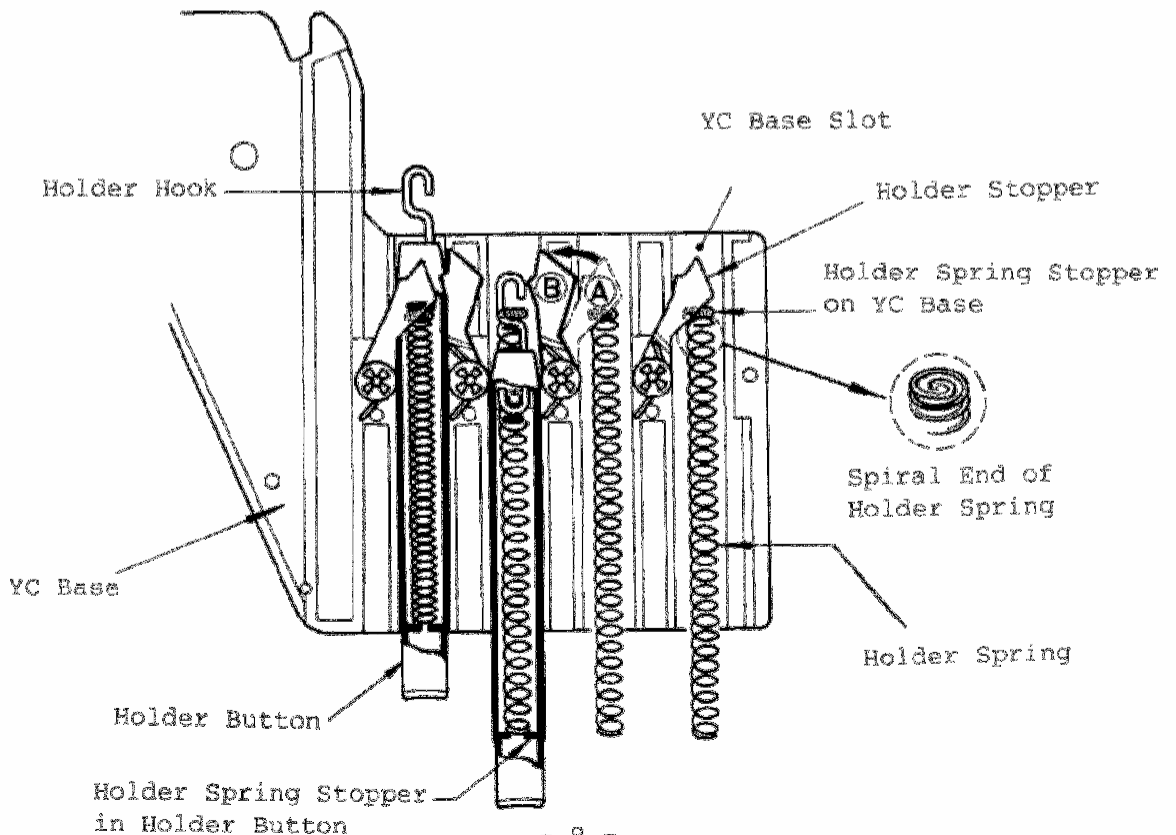

2. Lift up the hook side of Holder Button slightly above Holder Spring Stopper on YC Base.

At that time, take care not to raise the opposite side of Holder Button to prevent Holder Spring from jumping out.

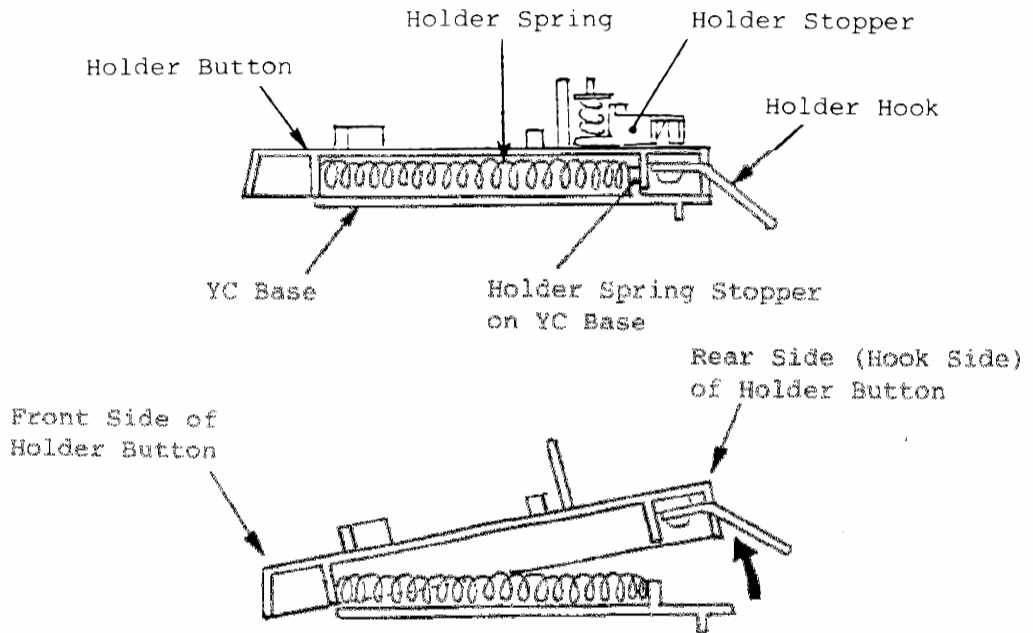

3. Remove Holder Button from YC Base by sliding it in the direction of the arrow with care taken to preserve 2.

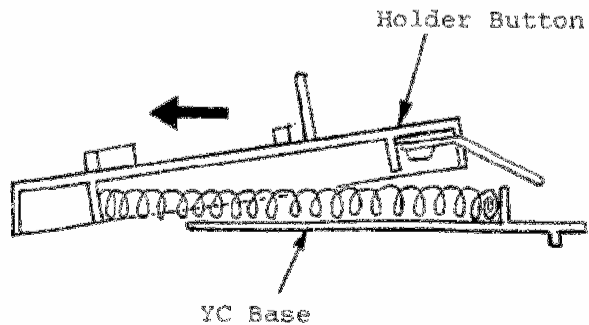

4. Return Holder Stopper from B to A position.
5. Remove Holder Spring.

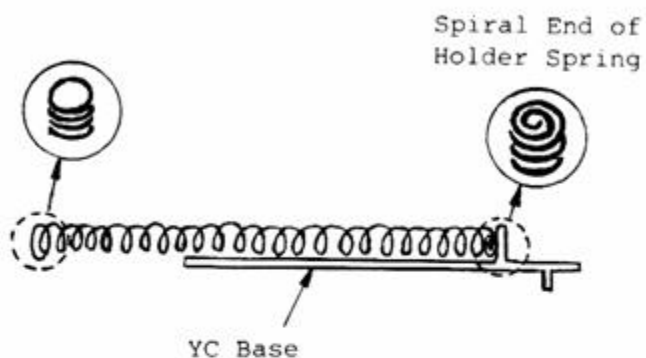

Installation: Reverse the procedure to install it.

(Notes at installation)

- \*Check the Holder Button for smooth travel in YC base slot.  
(Dust or lint in YC base slot may result in improper functioning.)
- \*Install the Holder Spring correctly with its spiral end set to the inside of Holder Spring Stopper on YC Base. (See above Figure)

#### (6) Holder Hook Removal and Installation

Removal: Remove Binding Head Tapping Screw 2, 3x6 securing Holder Hook.

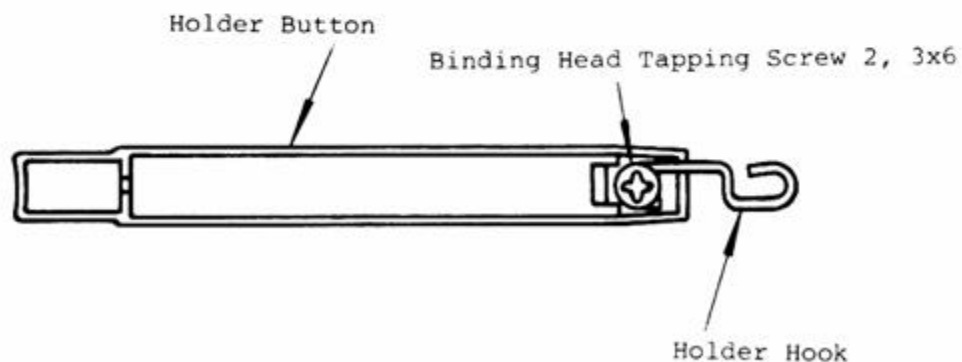

Installation: Secure Holder Hook to Holder Button with the screw 2, 3x6.

(Notes at installation)

\*Do not overtorque Binding Head Tapping Screw 2, 3x6. Overtightening of the screw may result in distortion of Holder Button as shown.

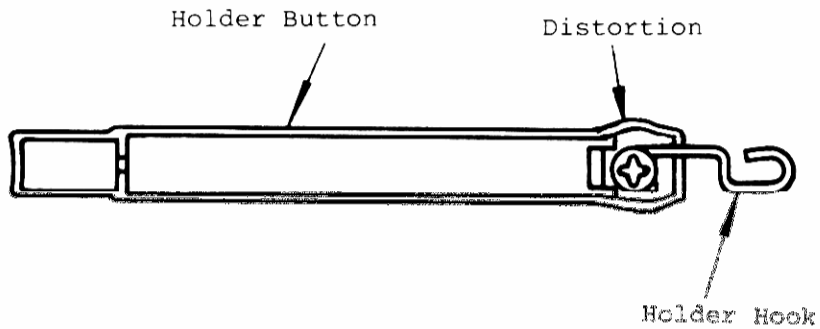

#### (7) Securing Base A, B Removal and Installation

1. Unscrew the Shift Lock Screw.
2. Remove E Snap Ring 3 using midjet 6screwdriver.
3. Pull out Securing Base Shaft. Securing Bases A and B will be separated.

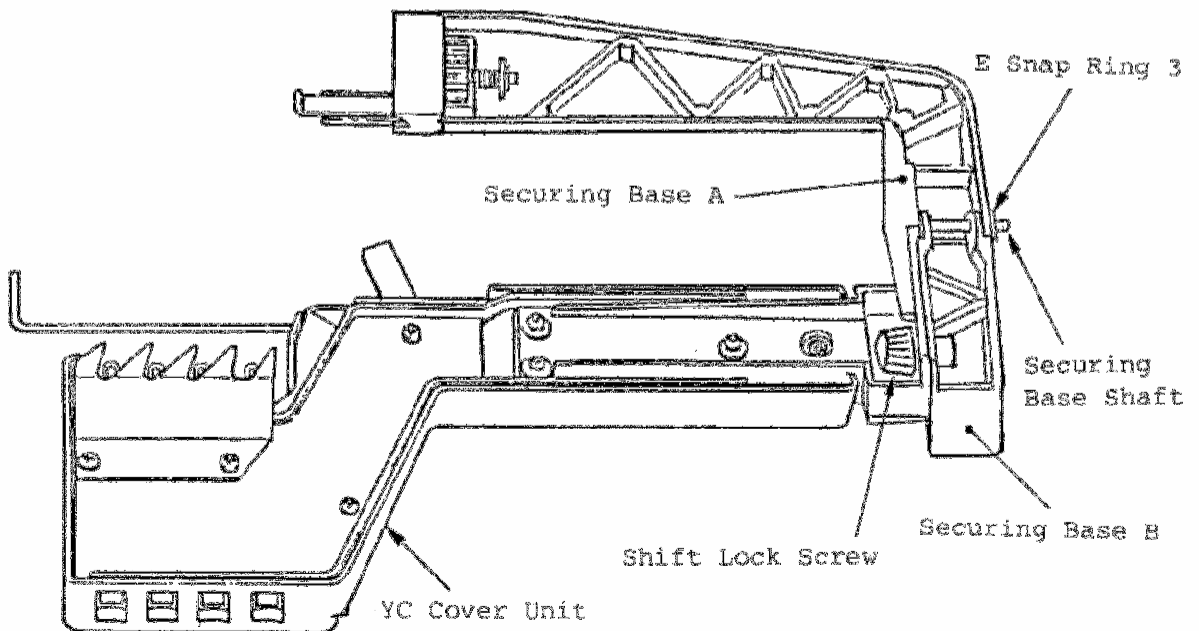

2-2 YC6 FUNCTIONAL CHECK POINTS

(1) Checking Feeding Lever

Feeding Lever must rotate smoothly and return to the reference position.

(2) Checking Holder Buttons

When pushing Reset Button with fingertip, the button must be set to position ①.

(3) Checking Reset Button

When pushing Reset Button in the arrow direction (⇨), Holder Button in position ① must return to position ②.

(4) Checking the travel of Holder Buttons

When actuating Feeding Lever, Holder Button must travel properly between positions ① and ②.

(5) Checking Securing Base B and Shift Lock Screw

Securing Base B must be shifted up and down freely when the Shift Lock Screw is loosened, and it must be secured to both positions S (for single-bed use) and D (for double-bed use) with the Shift Lock Screw.

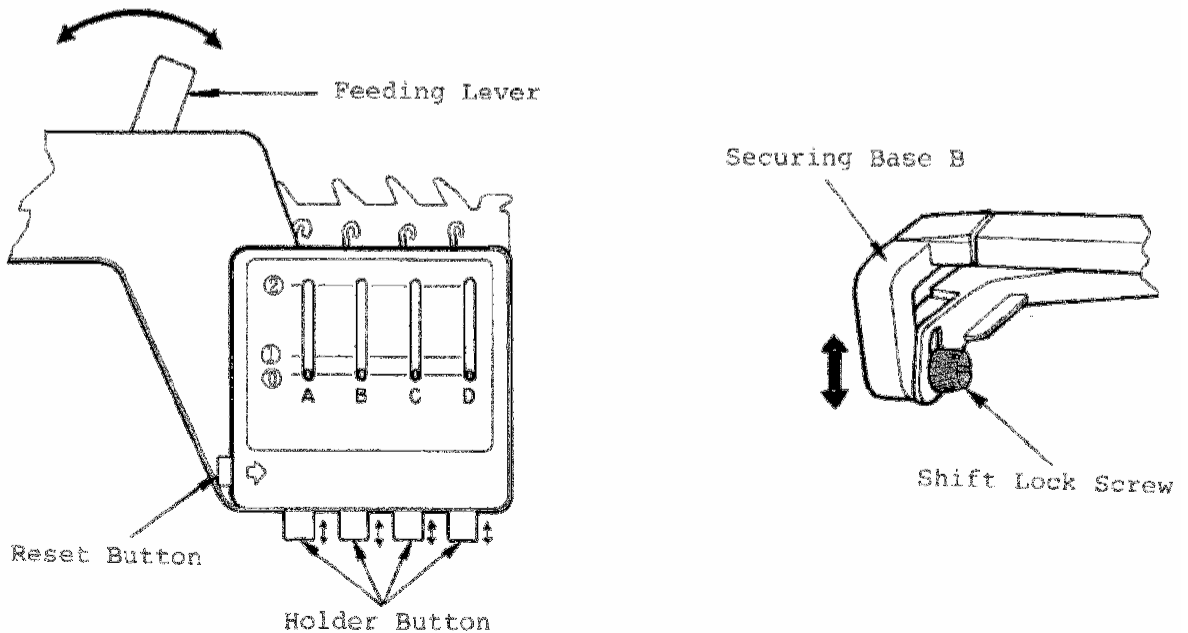

(6) Checking Securing Dial and Securing Hook

Securing Hook must be hooked on the knitter and secured firmly by fastening Securing Dial.

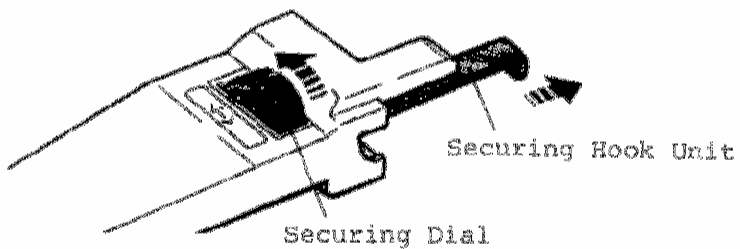
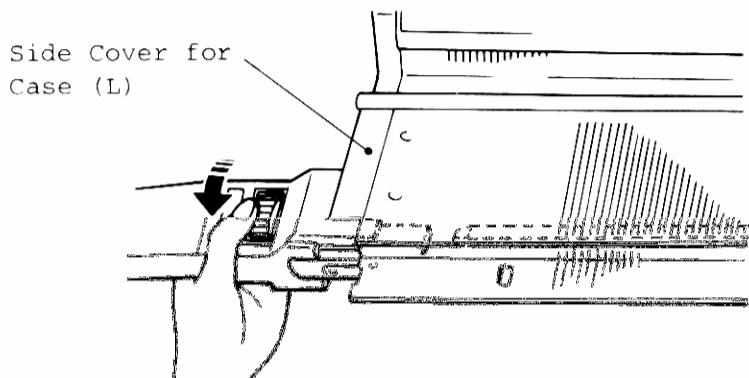



### 2-3 YC6 ADJUSTMENT WITH RIBBER ARM

Adjustment should be accomplished with SRP50 Ribber Arm to ensure ease and accuracy.

For adjusting method with YC Arm (in case Ribber Arm not available), refer to the explanation described in Item 2-4 "YC6 ADJUSTMENT WITH YC ARM".

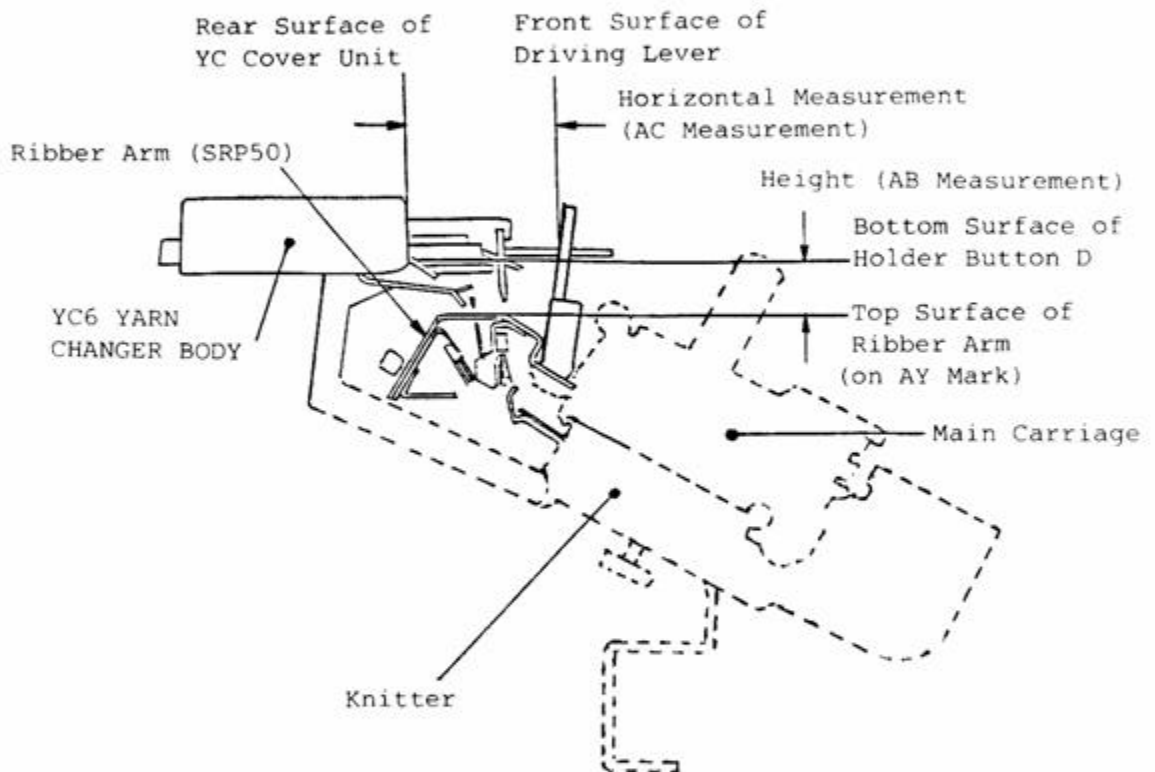

(1) Checking the Height of YC6 (AB Measurement)

1. Attach the Ribber Arm to Main Carriage, and move it to the left end. The measurement should be checked using Needle Pusher (0-1/1).

(Note) The YC6 must be set to position **D** for double-bed use.

2. Position the carriage so that the dot mark (AY Mark) on the arm comes just under the Holder Button "D" in extended position ②. Place the Needle Pusher at the right angle on the dot mark with its "0" side facing downward. Ensure that the bottom of Holder Button "D" is between the graduations (mm) 10 and 12. If not within the range, adjust the measurement following the procedure in step (3).

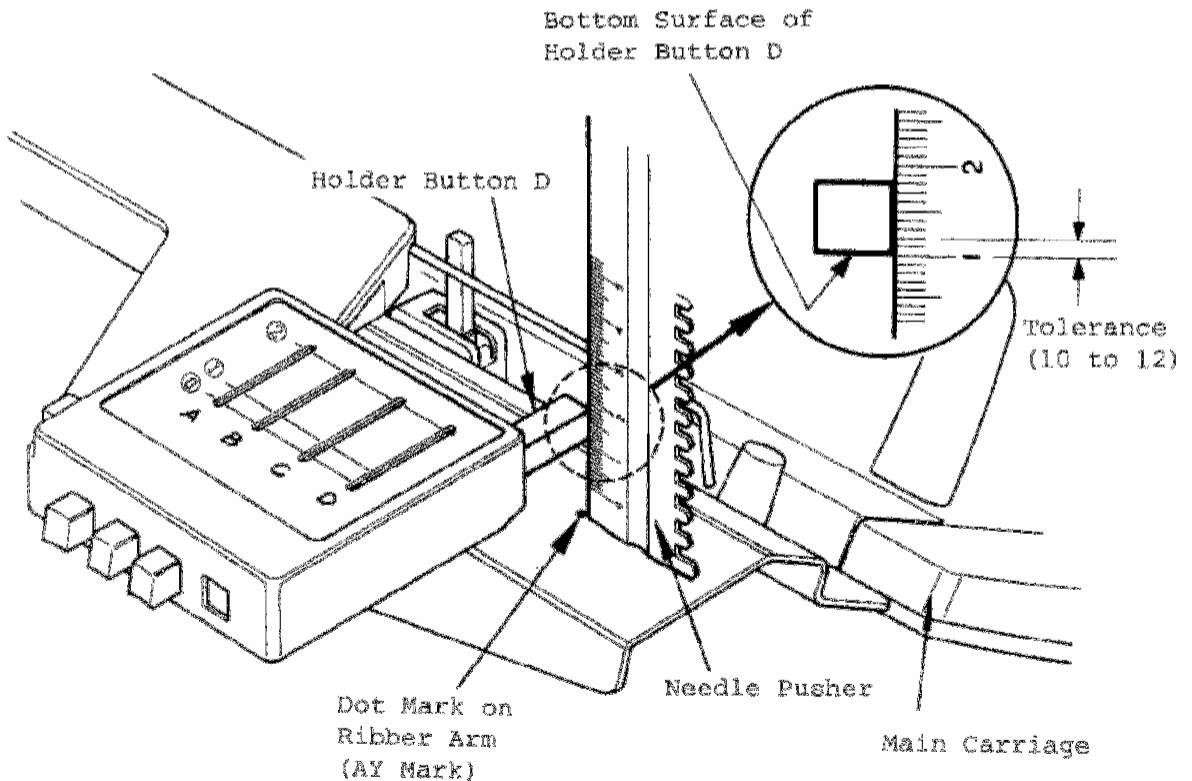

(2) Checking the Horizontal Measurement of YC6 (AC Measurement)

1. Raise the Driving Lever upright. Position the carriage so that Driving Lever and Holder Button "B" face each other.
2. Place the Needle Pusher at the right angle to the back of YC Cover Unit with its "0" side facing forward. Ensure that the front surface of Driving Lever is between the graduations (mm) 35 and 37. If not within the range, adjust the measurement following the procedure in step (3).

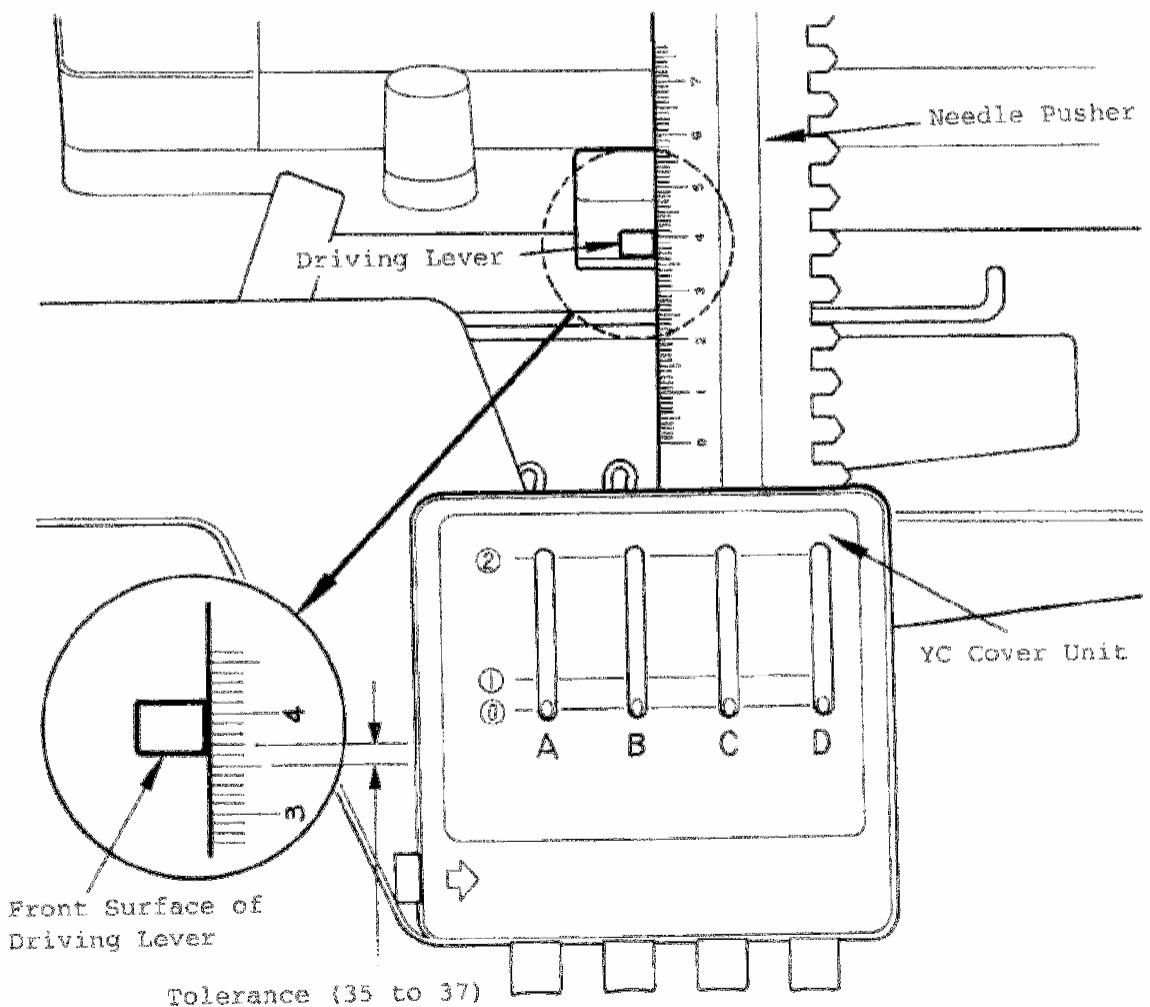

(3) Adjusting Method

1. Adjusting the Height of YC6 (AB Measurement)

Disengage the YC6 from the knitter. Remove three Collar Head STT Screws 3x13 securing the YC Base to Securing Base B.

Select and insert Plain Washers of appropriate thickness listed below. (two-screw side)

(Note) Whenever YC6 height has been adjusted, check the adjustment of its horizontal measurement.

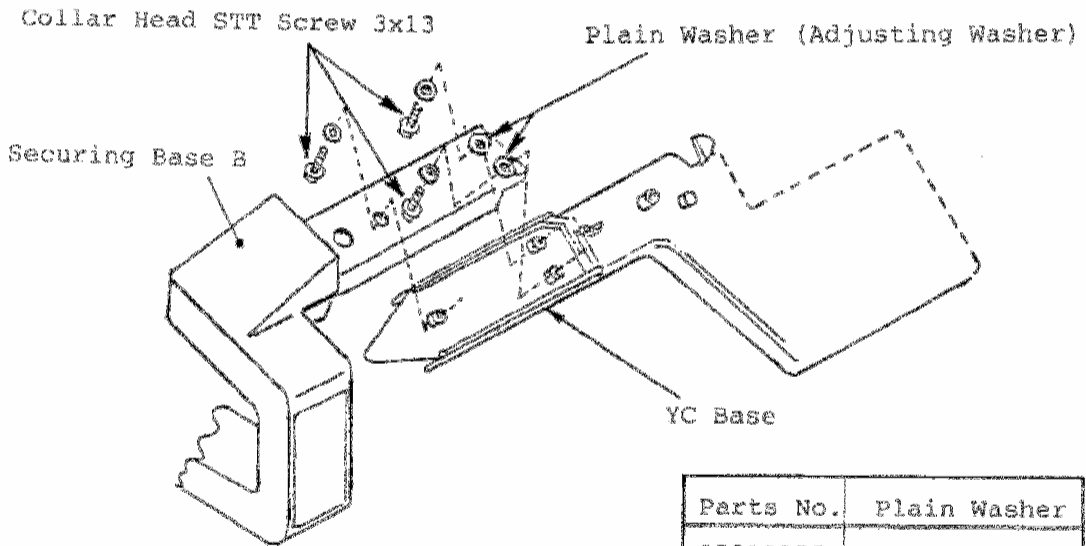

Parts No.	Plain Washer
05912159	4.2 x 8 x 0.2
04771002	4 x 8 x 0.5
04770814	4.3 x 8 x 0.8
05522156	4 x 8 x 1.0

## 2. Adjusting the Horizontal Measurement of YC6 (AC Measurement)

Loosen three Collar Head STT Screws 3x13 with the YC6 attached to the knitter, and move the YC Base back and forth to obtain the proper clearance.

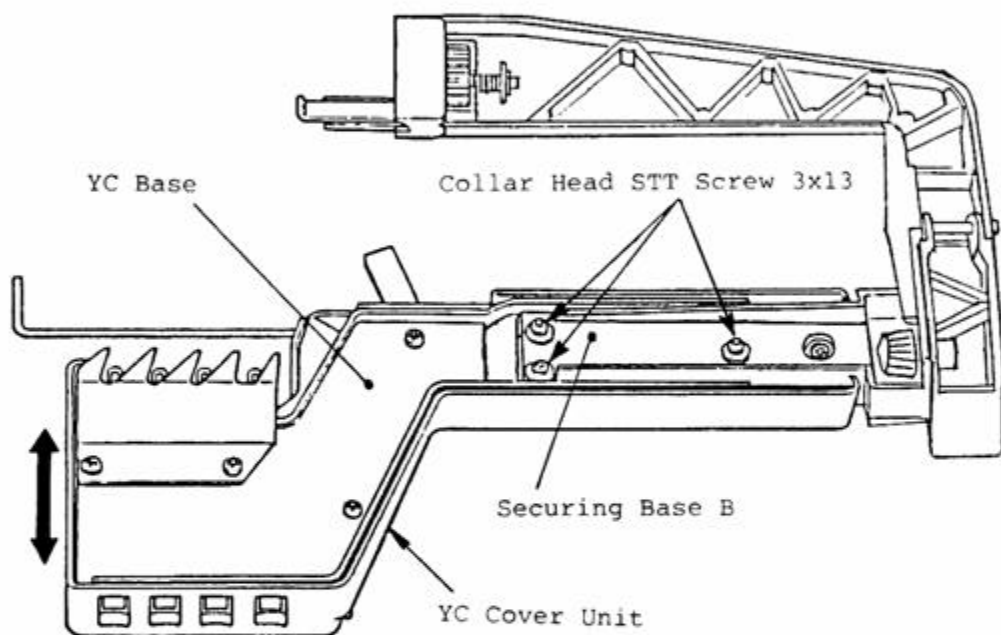

2-4 YC6 ADJUSTMENT WITH YC ARM

It is recommended to use SRP50 Ribber Arm for adjusting the YC6. But, should no Ribber Arm be available on hand, the adjustment can be accomplished with YC Arm in the following manner.

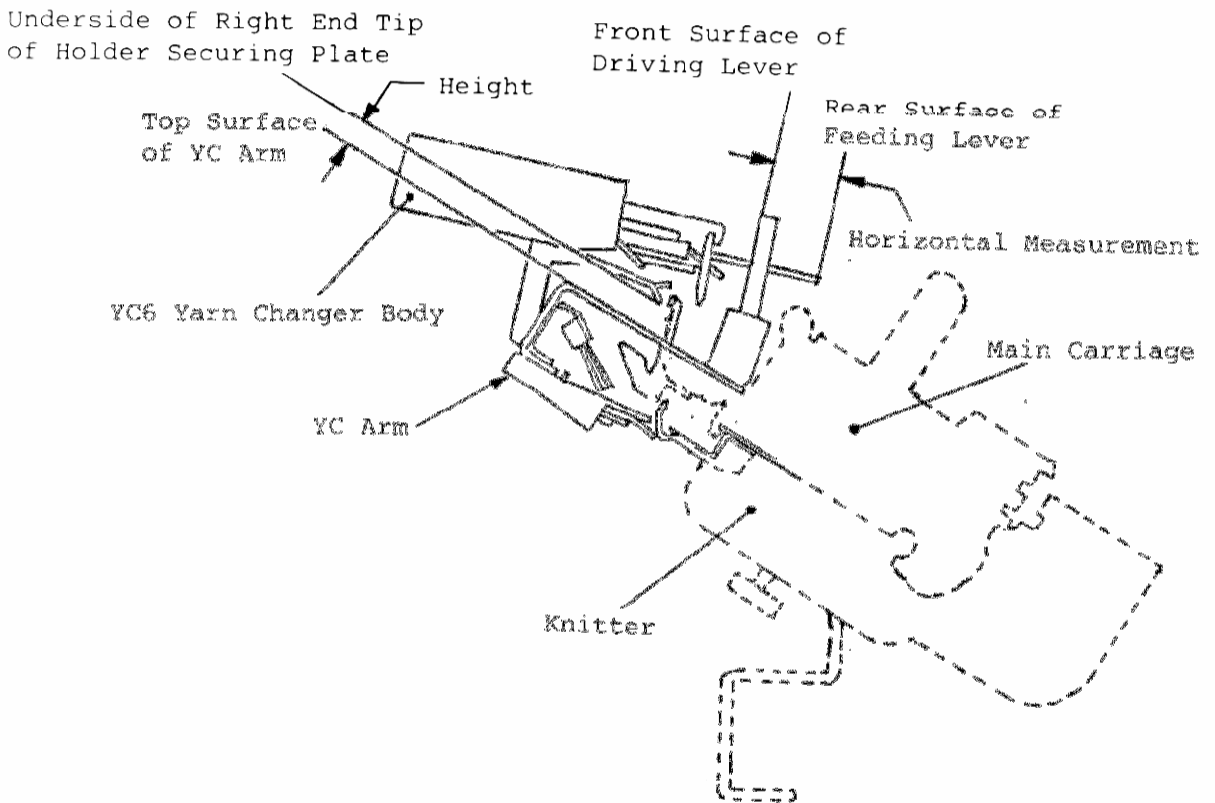

(1) Checking and Adjusting the Height of YC6

1. Attach the YC Arm to Main Carriage, and move it to the left end. The measurement should be checked using Needle Pusher (0-1/1).

(Note) The YC6 must be set to position S for single-bed use.

2. Place the Needle Pusher at the right angle to the arm with its "0" side facing downward as shown. Ensure that the underside of the right end tip of Holder Securing Plate is between the graduations (mm) 1 and 3.
3. If not within the range, adjust the measurement in the same manner described in Item 2-3, (3).

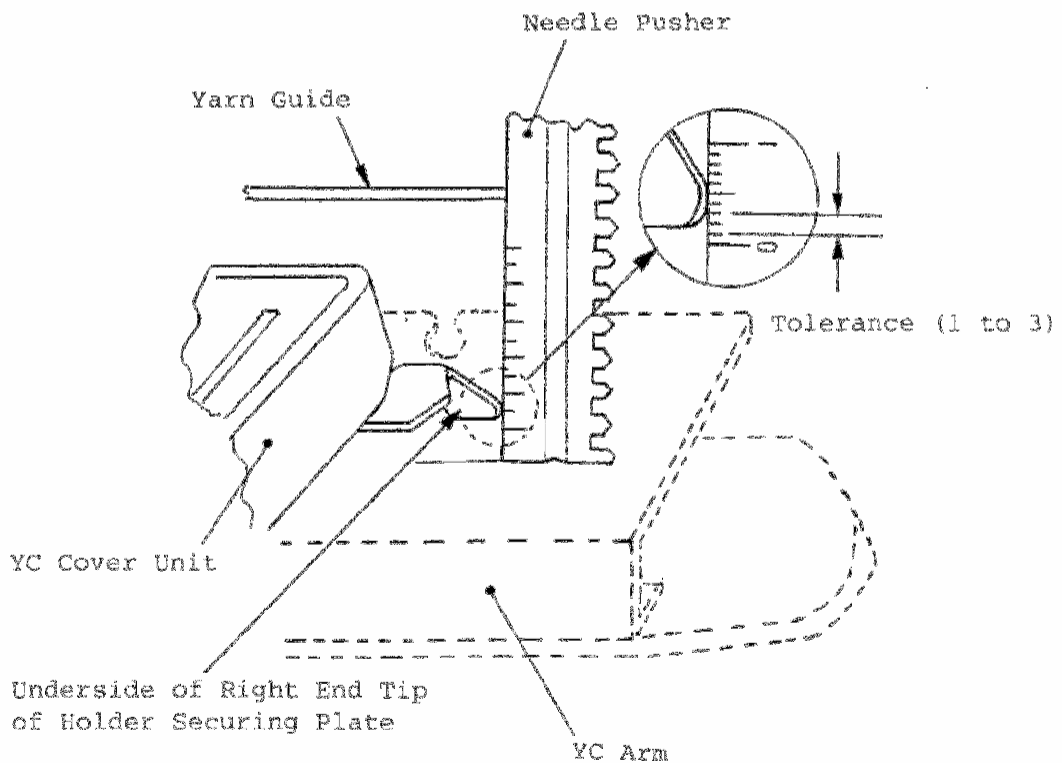

(2) Checking and Adjusting the Horizontal Measurement of YC6

1. Raise the Driving Lever upright, and move the carriage to the left end.
2. Move the carriage until Feeding Lever is positioned squarely to the back of YC Cover Unit by means of Driving Lever. Ensure that the clearance between the rear surface of Feeding Lever and the front surface of Driving Lever is between 20 and 22mm.
3. If not within the range, adjust the measurement in the same manner described in Item 2-3, (3).

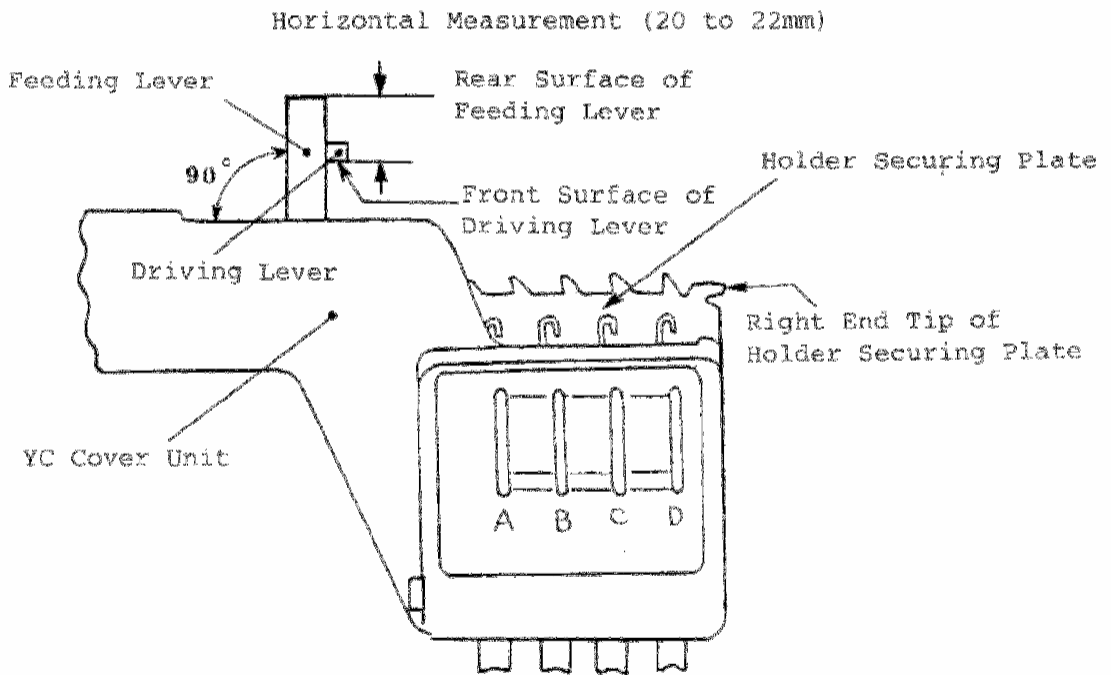



## 2-5 CHECK POINTS FOR POSSIBLE INTERFERENCE

If the adjustments have been made using Ribber Arm, it may be necessary to check for the interfering parts when the YC6 is set to position **S** with the YC Arm attached to Main Carriage. The following interference may be encountered owing to the scattering of the parts within tolerance or improper setting of YC Arm. Therefore, check the contact listed below, and recheck the YC6 for related adjustments and arm setting if necessary.

(Defects)

1. The contact between Holder Hook in extended position and Arm Nut.
2. The contact between the right end tip of Holder Securing Plate and Yarn Feeder A.
3. The contact between the tip of Yarn Guide and Arm Nut.

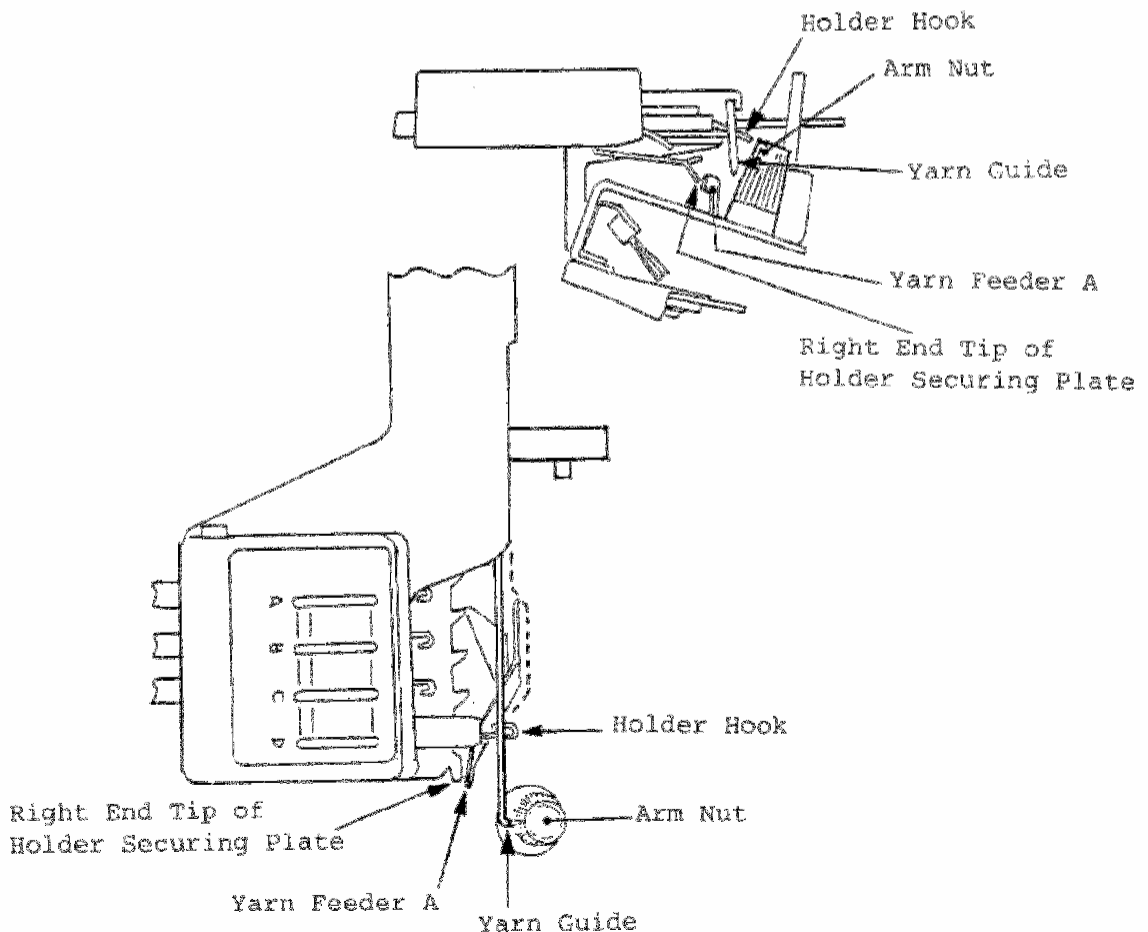

---

[3] YC ARM DISASSEMBLY, ASSEMBLY, AND ADJUSTMENT

---

3-1 YC ARM ADJUSTMENT

The adjustment is provided for Fabric Presser Unit and Yarn Feeders.

(1) Adjusting the Angle of Fabric Presser Unit (PN Adjustment)

The angle of Fabric Presser Unit must be adjusted so that the edge of the presser comes in a slight contact with the bottom of Latch Needles. To check the contact amount, measure the clearance between the front edge of the Needle Bed and the bottom of the needles using feeler gauge. Adjust the presser to obtain 0 to 0.3mm clearance.

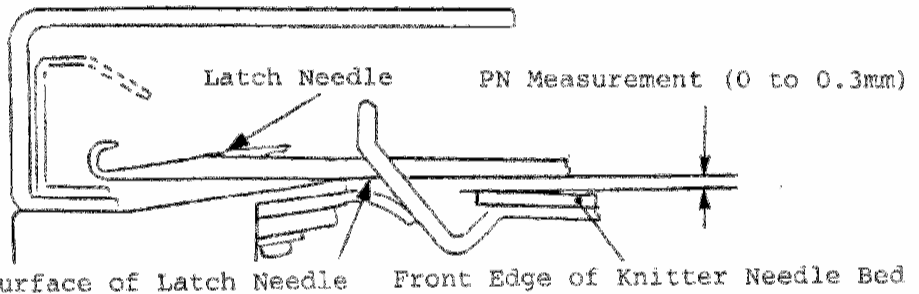

1. Push up approximately 60 needles around the center to D position and set the Russel Lever to "I".
2. When checking the angle of the left presser, move the carriage so that several needles at the left edge are positioned on the left presser as shown below and measure the clearance between the front edge of the Needle Bed and the needles using feeler gauge.

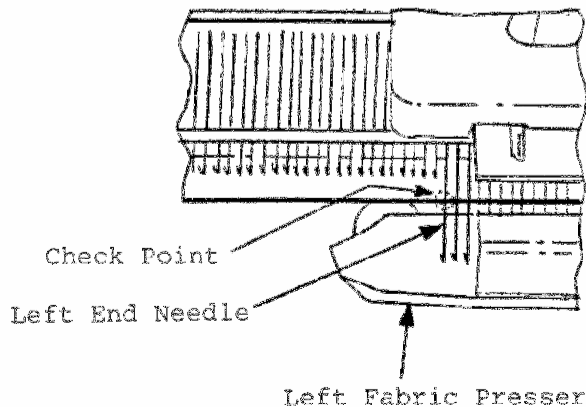

3. If the edge of the presser is out of contact with the needles, the adjustment must be made to obtain proper contact. Remove YC Arm from the carriage, and place it upside down as shown. Then, press down the presser by hand to provide necessary contact amount.

(Note) Do not apply too much force when depressing Fabric Presser Unit. Otherwise, the YC Arm may be bent more than necessary and consequently provide too much contact amount. Adjust the presser gradually with care.

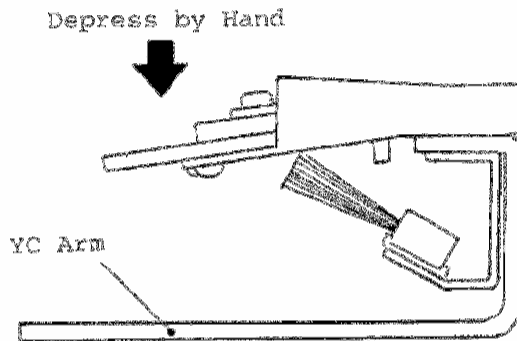

4. If the edge of the presser is in excessive contact with the needles, adjust the presser by depressing it with thumb, with YC Arm attached to the carriage.

(Note) In this case, also adjust the presser gradually with care. Do not apply too much force to the presser at a time.

5. When the adjustment of the presser angle has been completed, ensure that both right and left pressers are in a flat condition. If not, align them horizontally.

\*The same procedure is applicable to the right presser.

Align Horizontally



(2) Adjusting the Horizontal Measurement of Fabric Presser Unit  
(PS Adjustment)

Before attempting the adjustment, remove Round Rubbers and Fabric Gears by unscrewing four Collar Head Screws 3x5 to facilitate the adjustment. Then, set both Tuck Levers to the position indicated by broken lines so that the screw heads can be seen. Loosen six Binding Head Screws 3x6 and temporarily refasten the screws only slightly.

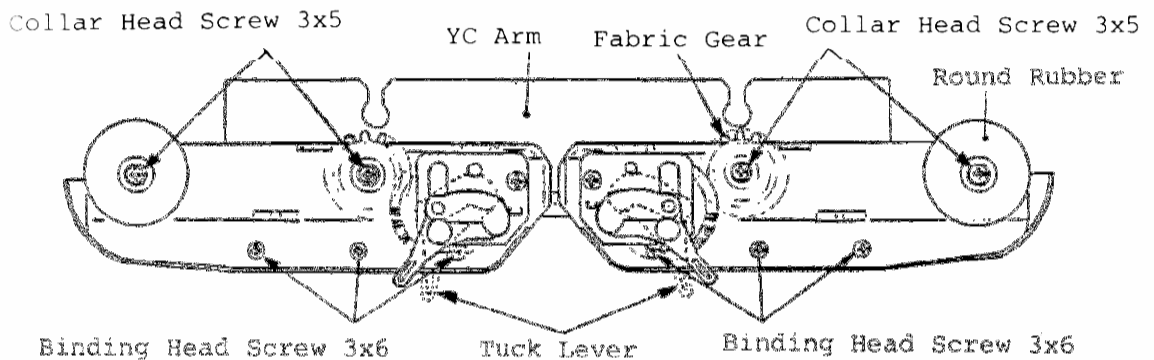

1. The clearance between the edge of Fabric Presser Unit and Sinker Posts of the knitter (PS Measurement) must be 1.5 to 2.0mm.

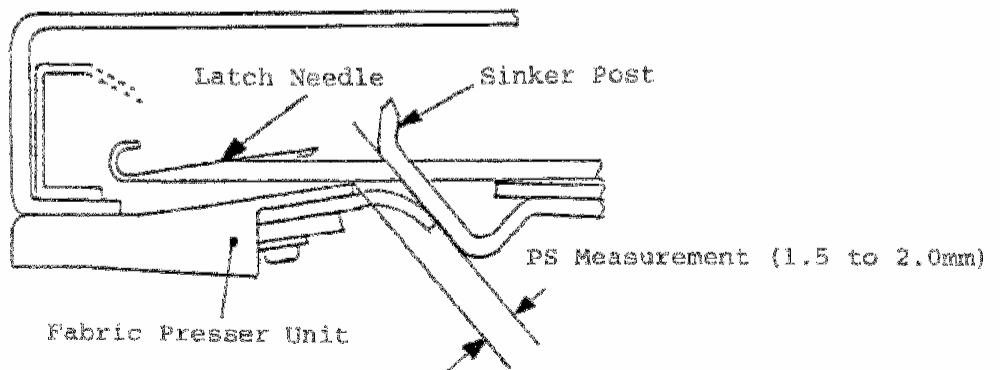

2. If the measurement is too wide, adjust the presser by tapping it with the handle of screwdriver, while inserting 1.70 to 1.75mm feeler gauge between the presser and sinkers.

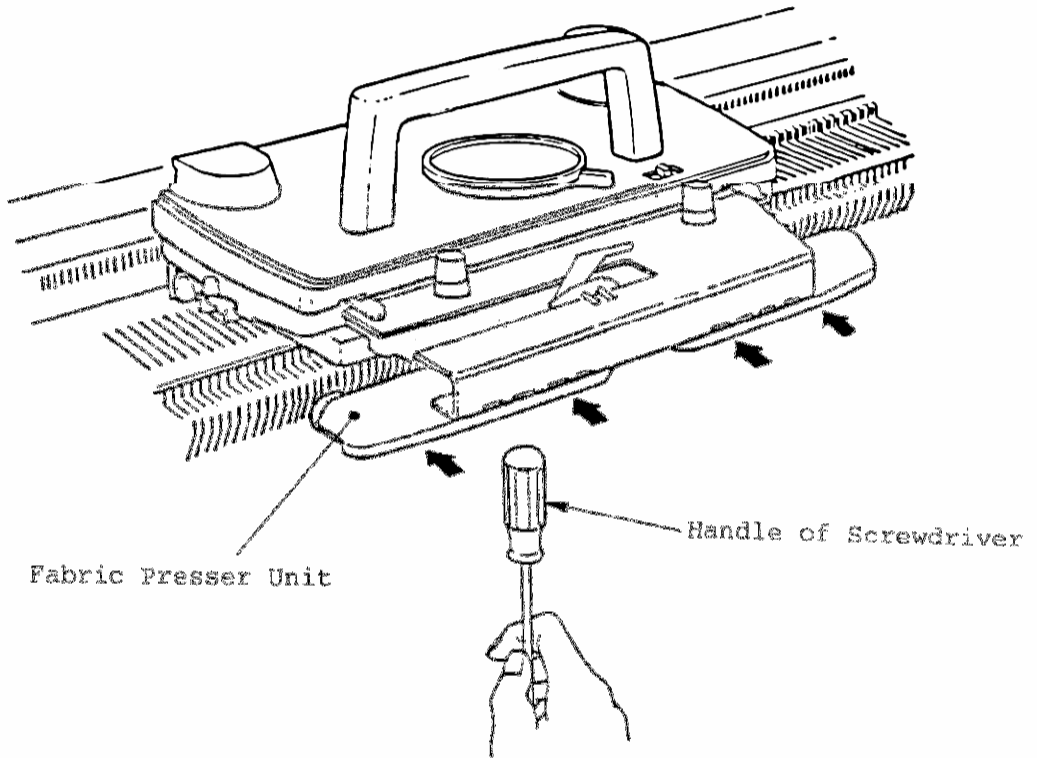

\*The adjustment for Yarn Feeders will be explained in Item 3-2,(3)(5).

### 3-2 YC ARM DISASSEMBLY AND ASSEMBLY

#### (1) Yarn Feeder A, B Removal

1. Place the YC Arm upside down and set both Tuck Levers to the position indicated by broken lines so that the screw heads can be seen. Remove six Binding Head Screws 3x6, and the Fabric Presser Unit will separate from YC Arm.

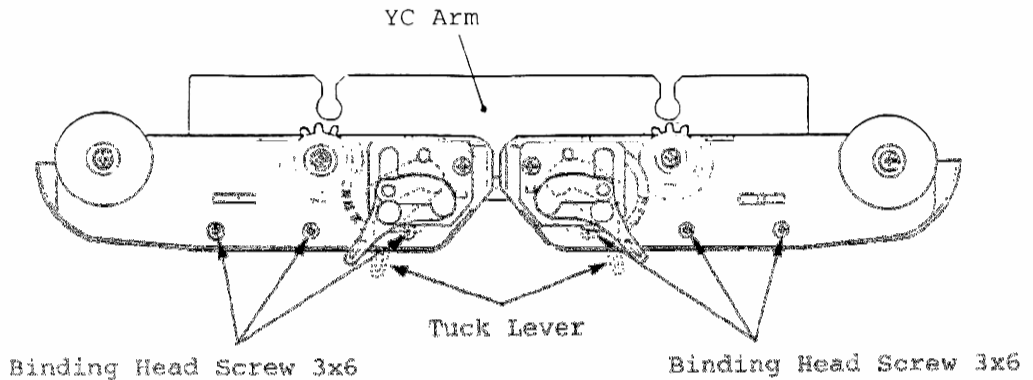

2. Remove two Binding Head Screws 3x5 shown in the Figure below. Latch Stopper, Latch Magnet Cover (containing Latch Magnets), and Yarn Feeder A will fall free from YC Arm.

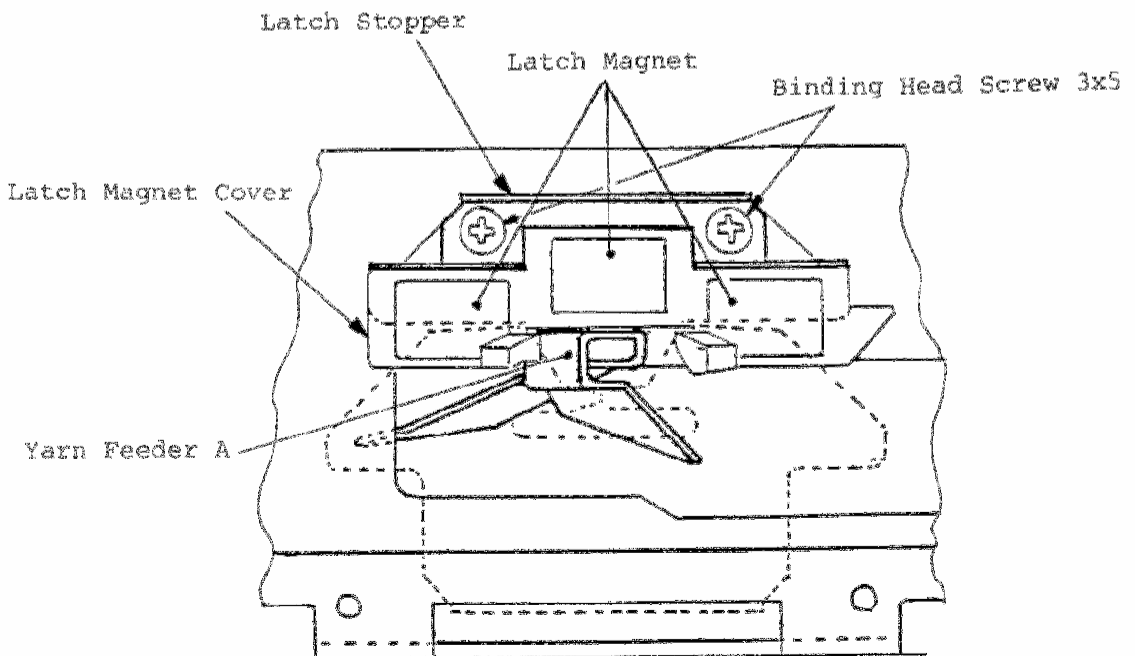

3. Turn over YC Arm and remove two Spec. Truss Head Screws 3x6.  
Yarn Feeder B and Yarn Feeder Guide will fall free from YC Arm.

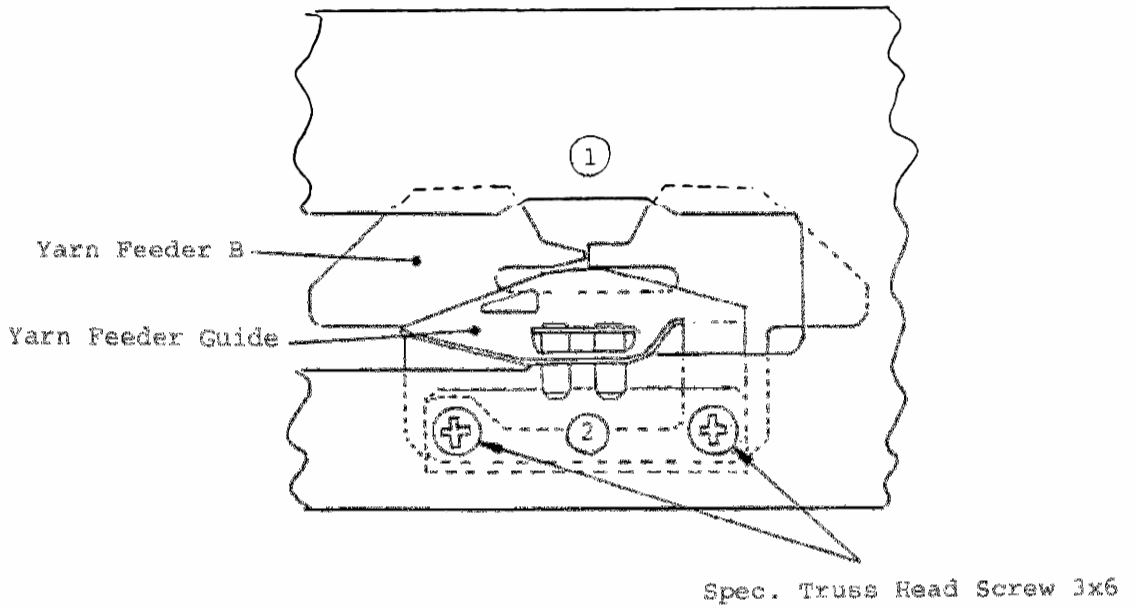

(2) Yarn Feeder B Installation

As shown in Figure A, insert the Yarn Feeder Guide between Yarn Feeder B and YC Arm, and secure them with two Spec. Truss Head Screws 3x6.

At installation, adjust the Yarn Feeder Guide to obtain a slight contact at the right edge, and a slight clearance at the left edge with Yarn Feeder B.

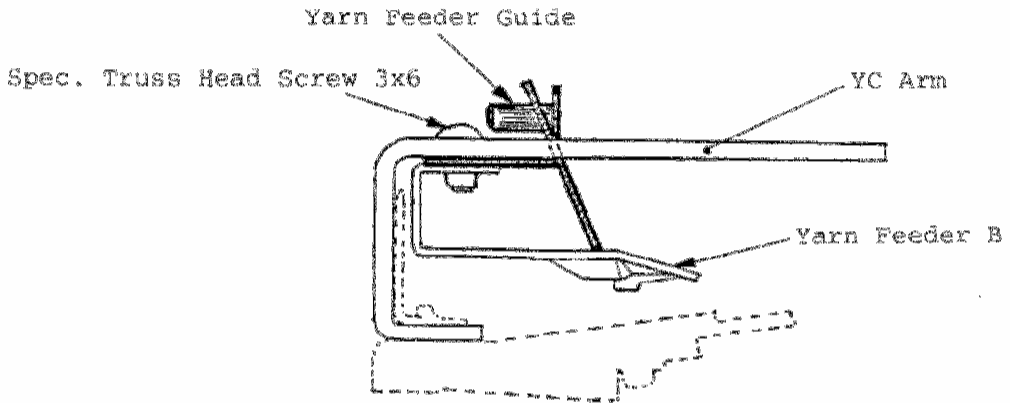

(Figure A)

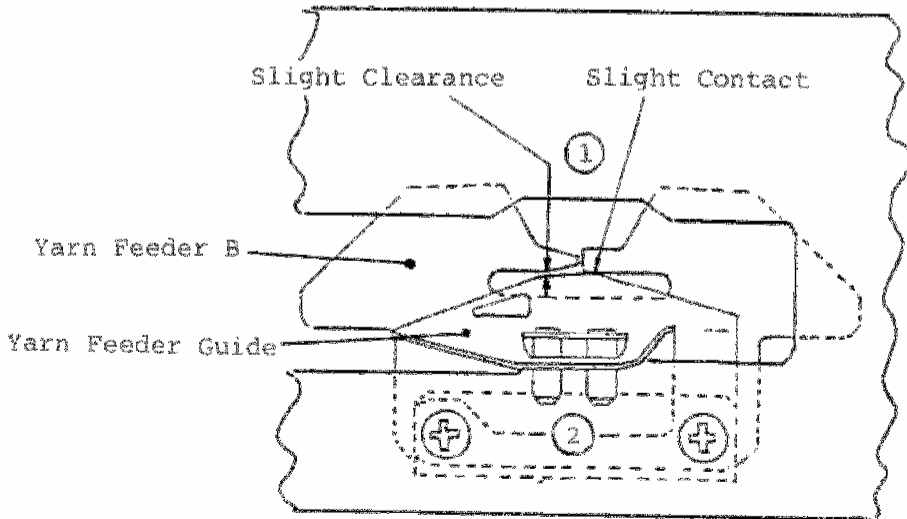

(Figure B)



(3) Adjusting Yarn Feeder B

1. As the Yarn Feeder B is the factory-determined adjustment, it must be left alone. The measurements shown will rarely vary with normal use of the YC6.

In Fair Isle, if the stitches knitted with ground yarn in Yarn Feeder (2) are dropped frequently, or the needle latches are apt to be damaged, ensure that the arm setting and the presser angle are correct first. Then, check the following measurements.

Spec. Truss Head Screw 3x6

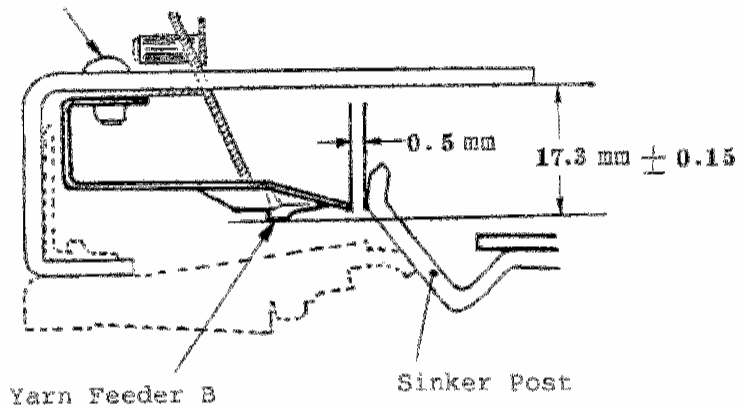

\*The clearance between the bottom of  
Yarn Feeder B and YC Arm.....17.3mm ±0.15

\*The clearance between the tip of Yarn Feeder B  
and Sinker Posts of the knitter.....0.1 to 0.5mm

2. When checking and adjusting 17.3mm ±0.15 clearance, remove Fabric Presser Unit, Latch Magnet Cover, Yarn Feeder A, and Latch Stopper for easier work. The adjustment can be accomplished by lifting up or lowering down the Yarn Feeder B with fingertip.

(4) Yarn Feeder A Installation

Place the YC Arm upside down as shown, and put the Yarn Feeder A, Latch Magnet Cover (Latch Magnets as well, with the red side facing up), and Latch Stopper on the YC Arm in sequence, aligning the holes. Secure them with two Binding Head Screws 3x5.

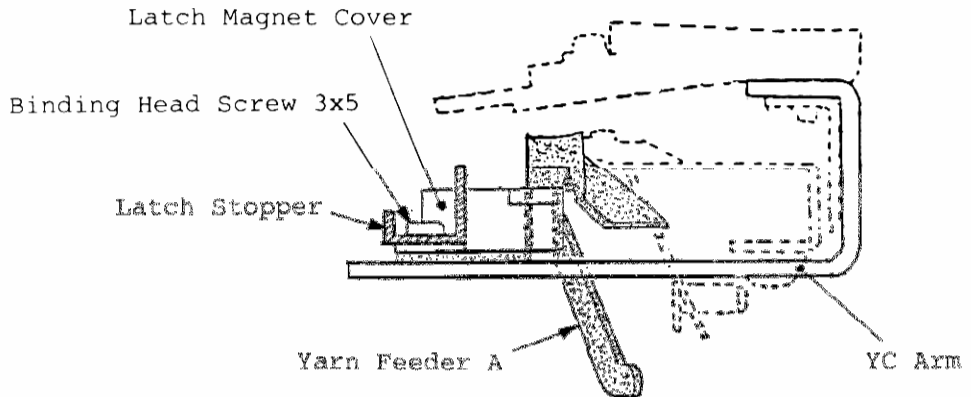

(5) Checking the Height of Yarn Feeder A

The clearance between the bottom of Yarn Feeder A and YC Arm must be 16.65 to 16.95mm. If not within the range, replace the Yarn Feeder A with new one.

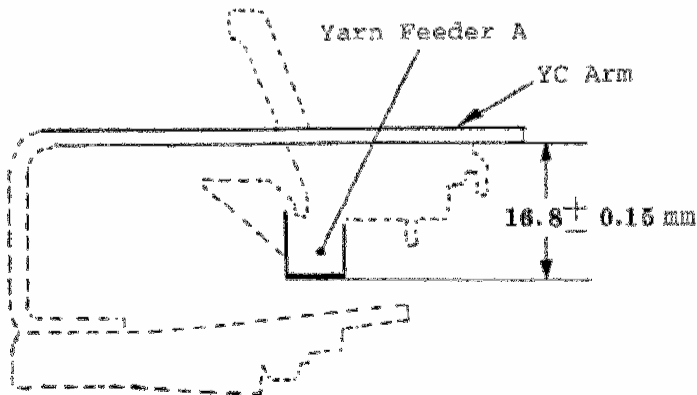





[4] NECESSARY NOTES WHEN OPERATING YC6

(1) Improving Knitting Conditions

For the yarn slack of the first row after changing yarns, instruct the operator to make a tension adjustment by hand.

(Refer to YC6 Instruction Book, P.9)

As the Tension Springs of 4-color Auto-Tension are stronger than those of 2-color Auto-Tension, also instruct the following operational arrangements to prevent the edge stitches from dropping or floating.

	Stockinet	Tuck Stitch	Slip Stitch	Fair Isle
Tuck Lever (YC Arm)	When knitting in tighter stitch density: 		When the edge stitches drop: 	
Claw Weight	Hang the Claw Weights on each side of the fabric.			
Edge Needle Arrangement	Not Required	Push up 2 edge needles on opposite side of the carriage to D position.	Push up 1 edge needle on opposite side of the carriage to D position	Push up 1 edge needle on the carriage side to D position.
Tension Adjustment	Make the tension adjustment by hand to prevent the yarns from being entangled to the gears and the brushes.			

(2) Knitting in Fair Isle, or Knitting Fluffy Yarns

When knitting in Fair Isle, or knitting fluffy yarns like Mohair, instruct the operator to use Separator Hook to improve knitting conditions. (Refer to YC6 Instruction Book, P.9)

(3) Dropped Stitches in Knitting without Tension Adjustment by Hand

Should the dropped stitches occur under good knitting conditions (using 2 yarns) without manual tension adjustment, they may result from incorrect threading through the YC6 (Holder Hooks and the teeth of Holder Securing Plate) as illustrated below.

\*Main Possible Causes of Trouble Shown in Figure A at Left

° (Cause)

The carriage is moved to the left more than necessary after yarn changing.

° (Remedy)

Instruct the operator to return the carriage when the click sound has been heard upon completion of yarn changing.

° (Cause)

Holder Buttons do not return smoothly.

° (Remedy)

Check and adjust the Holder Buttons as necessary.

\*Main Possible Causes of Trouble Shown in Figure B at Right

° (Cause)

The height and horizontal measurement of the YC6 are not correct.

° (Remedy)

Check and adjust the measurements as necessary.

(Refer to Item 2-3 "YC6 ADJUSTMENT")

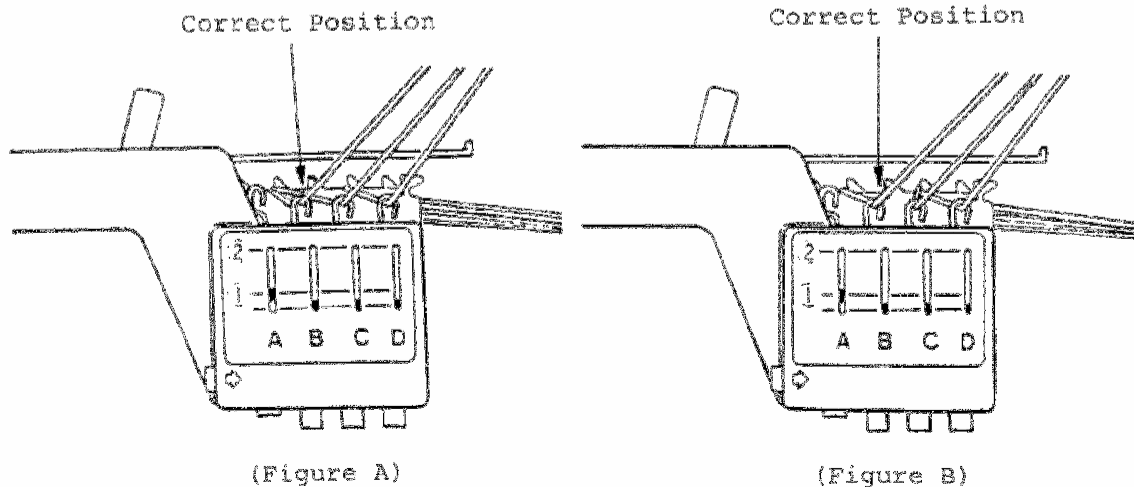

(4) Left End of Knitting Width

Appropriate position for the left end of knitting width is between 90th and 10th needles at the left side of center "0", when using the YC6.

If the position is further to the left, the stitches at the left edge may drop due to difficulty of yarn changing.

If further to the right, the knitting conditions become worse due to increase of the yarn slack.

Particularly in Partial Knitting, instruct the operator to make manual tension adjustment as the yarns are apt to become loose.

---

[5] APPLICABLE MODELS

---

(1) Knitting Machines Applicable to YC6

MOD.321-360 (Punch-card Knitter ..... P=4.5mm)

MOD.500-560 (Electronic Knitter)

(2) Knitting Machines Applicable to YC6 Subject to Ribber Arm Used

MOD.370 (Punch-card Knitter ..... P=3.6mm)

(3) Ribbing Attachments Applicable to YC6

SRP20/50 (P=4.5mm)

FRP70 (P=3.6mm)

18

19

20

22

23

24

25

26

27

28

29

30

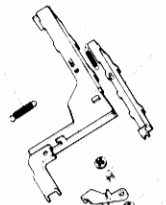
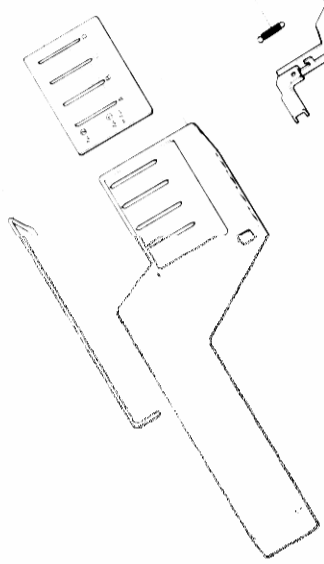

13

14

15

16

17

12

9

6

10

36

31



12

13

14

15

16

17



1

2

3

4

5

6

35

32

YARN CHANGER GROUP

Ref. No.	Parts No.	Qty	Description	Unit Price
1	01283142	1	Securing Hook Unit	
2	01263144	1	Securing Dial	
3	04621207	1	Plain Washer 4x10x0.8	
4	05811005	1	E Snap Ring 2.5	
5	01323518	1	Securing Seal	
6	04083507	1	Securing Base A	
7	04140413	3	Collar Head STT Screw 3x13	
8	01040419	2	Binding Head Tapping Screw 2, 3x8	
9	04063509	1	Holder Securing Plate	
10	02142453	1	Binding Head STT Screw 3x6	
11	04771002	3	Plain Washer 4x8x0.5	
12	01293505	2	Binding Head Tapping Screw 2,3x15	
13	01103506	1	Feeding Lever Spring	
14	01093509	1	Feeding Lever	
15	01113505	1	Feeding Gear	
16	01273507	4	Binding Head Tapping Screw 2, 3x6	
17	01073501	4	Holder Hook	
18	04033502	1	Yarn Guide	
19	05013503	1	YC Plate (SILVER-REED)	
	05113501	1	YC Plate (SINGER)	
	05213509	1	YC Plate (EMPISAL-KNITMASTER)	
	04043501	1	YC Cover Unit (incl.Reset Button)	
22	01153501	1	Feeding Slider Spring	
23	01123504	1	Feeding Slider	
24	01143502	1	Pre-set Spring	
25	01133503	1	Pre-set Bar	
26	02221000	4	CS Snap Ring 3	
27	01053503	4	Stopper Spring	
28	01043504	4	Holder Stopper	
29	04023503	4	Holder Button	
30	04213500	4	Holder Spring.	
31	01033505	1	YC Base	
32	04093506	1	Securing Base B	
33	04103503	1	Securing Base Shaft	
34	04113502	1	Shift Lock Screw	
35	08662116	1	E Snap Ring 3	
36	05033501	1	Shift Change Seal	

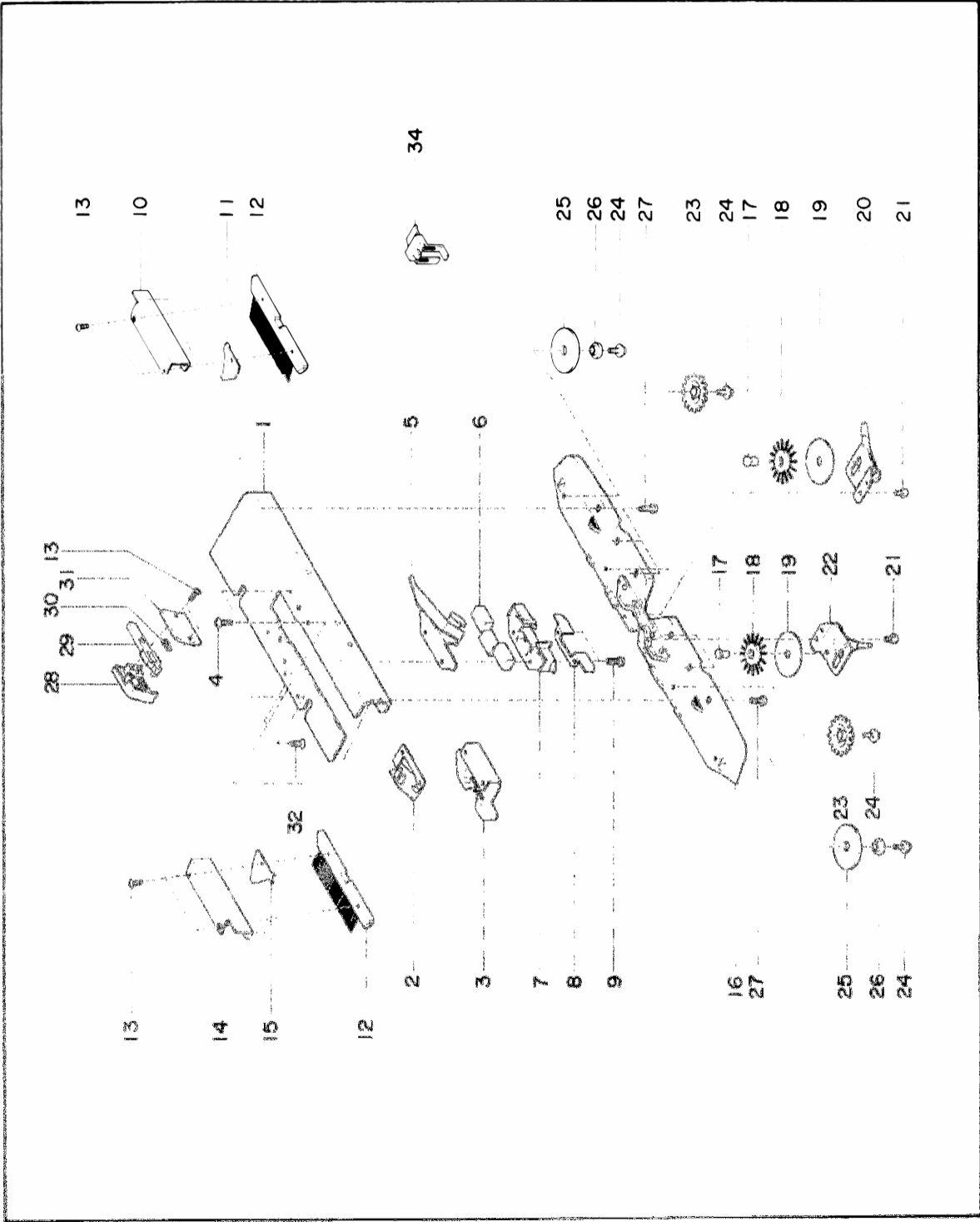



YC ARM GROUP

Ref. No.	Parts No.	Qty	Description	Unit Price
©	06003503	1	YC Arm Unit (No.1-32)	
1	06013502	1	YC Arm	
2	06183503	1	Yarn Feeder Guide	
3	06173504	1	Yarn Feeder B	
4	02511061	2	Spec. Truss Head Screw 3x6	
5	06143507	1	Yarn Feeder A	
6	06163503	3	Latch Magnet	
7	06153506	1	Latch Magnet Cover	
8	06253504	1	Latch Stopper	
9	05212006	2	Binding Head Screw 3x5	
10	06043509	1	Brush Holder (R)	
11	06063507	1	Latch Guide (R)	
12	06260814	2	Clearing Brush	
13	06096002	6	Round Head Tapping Screw 2, 2.3x6	
14	06053508	1	Brush Holder (L)	
15	06073506	1	Latch Guide (L)	
16	06083505	1	Fabric Presser Unit	
17	06040414	2	Tuck Brush Pin	
18	06121206	2	Round Brush B	
19	17361205	2	Round Brush Cover	
20	06220412	1	Tuck Brush Base (R)	
21	04740205	2	Binding Head Screw 3x3	
22	06230411	1	Tuck Brush Base (L)	
23	06251201	2	Fabric Gear	
24	08030611	4	Collar Head Screw 3x5	
25	06123509	2	Round Rubber	
26	06133508	2	Round Rubber Collar	
27	01332006	6	Binding Head Screw 3x6	
28	06223507	1	Driving Lever Base	
29	06243505	1	Driving Lever	
30	04561205	1	Driving Lever Spring	
31	06233506	1	Driving Lever Cover	
32	04153508	2	Flat Head Countersunk Tapping Screw 2, 2.6x10	
34	06543508	2	Separator Hook	

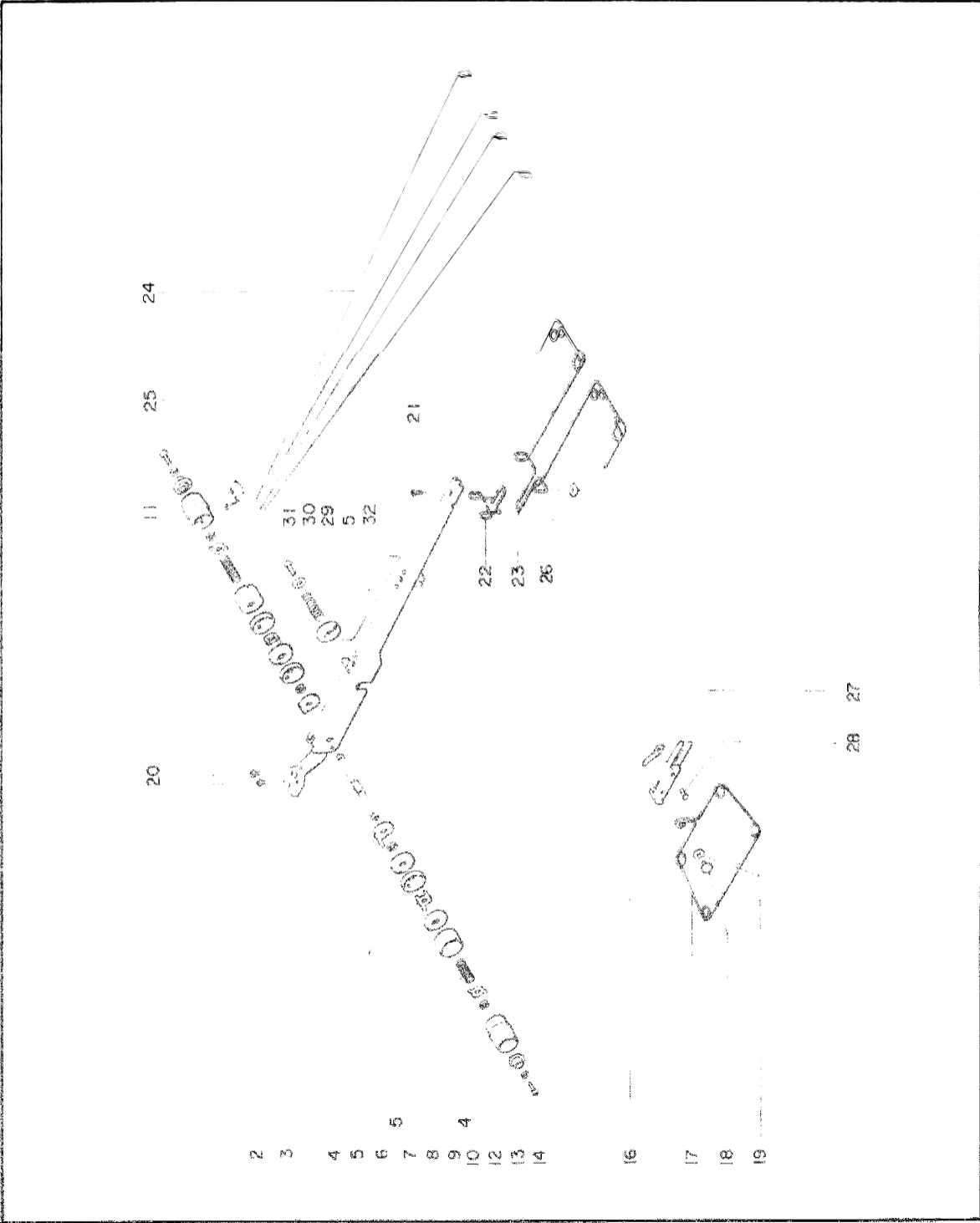

YC TENSION/ACCESSORY GROUP

Ref. No.	Parts No.	Qty	Description	Unit Price
○	06403505	1	YC Tension Unit (No.2-14, 20-26, 29-32, incl. YC Tension Arm)	
○	07123508	1	YC Yarn Rod	
○	<del>07033506</del> 07303506	1	YCT Guide Unit (No.16-19, 27-28)	
2	07103500	1	YCT Shaft	
3	07112006	2	Yarn Stopper Plate	
4	08672115	4	E Snap Ring 4	
5	07092000	1	Tension Disc B	
6	07093503	2	YC Yarn Stopper Plate	
7	07082001	2	Tension Disc A	
8	07033509	2	YCT Disc Spring	
9	07111602	2	YCT Disc Spring Stopper	
10	07081607	1	Tension Dial (L)	
11	07071608	1	Tension Dial (R)	
12	07151608	2	Dial Stopper	
13	07581606	2	Spring Washer 2, 3	
14	06291009	2	Binding Head Screw 3x8	
16	07313505	1	YC Yarn Retainer	
17	07323504	1	YCT Guide	
18	07353501	1	YCT Guide Rivet	
19	08611204	1	Shaft Lock Washer 5	
20	07203508	2	Binding Head Screw 2.6x4	
21	07173503	1	Oval Head Countersunk Screw 3x8	
22	07162001	1	Round-shaped Yarn Guide	
23	07043508	1	V-shaped Yarn Guide	
24	07023500	2	YC Tension Spring	
25	07083504	1	YCT Securing Plate	
26	02036002	1	Square Nut 3, 8x8x2	
27	07343502	1	YC Yarn Retainer Spring	
28	05791009	1	Thin Flat Fillister Head Rivet 2.6x4	
29	06433502	1	YCT Auxiliary Disk Spring	
30	04804001	1	Plain Washer 3.2x11x0.5	
31	04782561	1	Binding Head Screw 3x4	
32	05043500	1	YCT Seal	
	07105448	2	Ribber Clamp	
	07613144	1	Check Card	
	06633507	1	Instruction Book	